



US 20200203627A1

(19) **United States**

(12) **Patent Application Publication**
MIYAZAKI et al.

(10) **Pub. No.: US 2020/0203627 A1**
(43) **Pub. Date: Jun. 25, 2020**

(54) **ORGANIC ELECTROLUMINESCENCE
DEVICE AND POLYCYCLIC COMPOUND
FOR ORGANIC ELECTROLUMINESCENCE
DEVICE**

(71) Applicants: **Samsung Display Co., Ltd.**, Yongin-si
(KR); **KYUSHU UNIVERSITY,
NATIONAL UNIVERSITY
CORPORATION**, Fukuoka-shi (JP)

(72) Inventors: **Yuuki MIYAZAKI**, Yokohama (JP);
Yoshimasa FUJITA, Yokohama (JP);
Kyohei MATSUO, Fukuoka-shi (JP);
Takuma YASUDA, Fukuoka-shi (JP)

(21) Appl. No.: **16/597,714**

(22) Filed: **Oct. 9, 2019**

(30) **Foreign Application Priority Data**

Dec. 21, 2018 (KR) 10-2018-0167210

Publication Classification

(51) **Int. Cl.**
H01L 51/00 (2006.01)
C07F 5/02 (2006.01)
C09K 11/06 (2006.01)
(52) **U.S. Cl.**
CPC *H01L 51/0072* (2013.01); *C07F 5/02*
(2013.01); *H01L 51/5004* (2013.01); *C09K*
2211/1018 (2013.01); *C09K 11/06* (2013.01)

(57) **ABSTRACT**

An organic electroluminescence device in which a polycyclic compound including an electron donor and an electron acceptor is included in an emission layer is provided. The electron donor contains an acridine derivative or a dibenzazasiline derivative, and the electron acceptor contains B as a ring-forming atom, O or S directly bonded to B, and a heterocyclic group in which three or five hexagonal rings are condensed. Accordingly, an organic electroluminescence device having high efficiency may be achieved.

10
↙

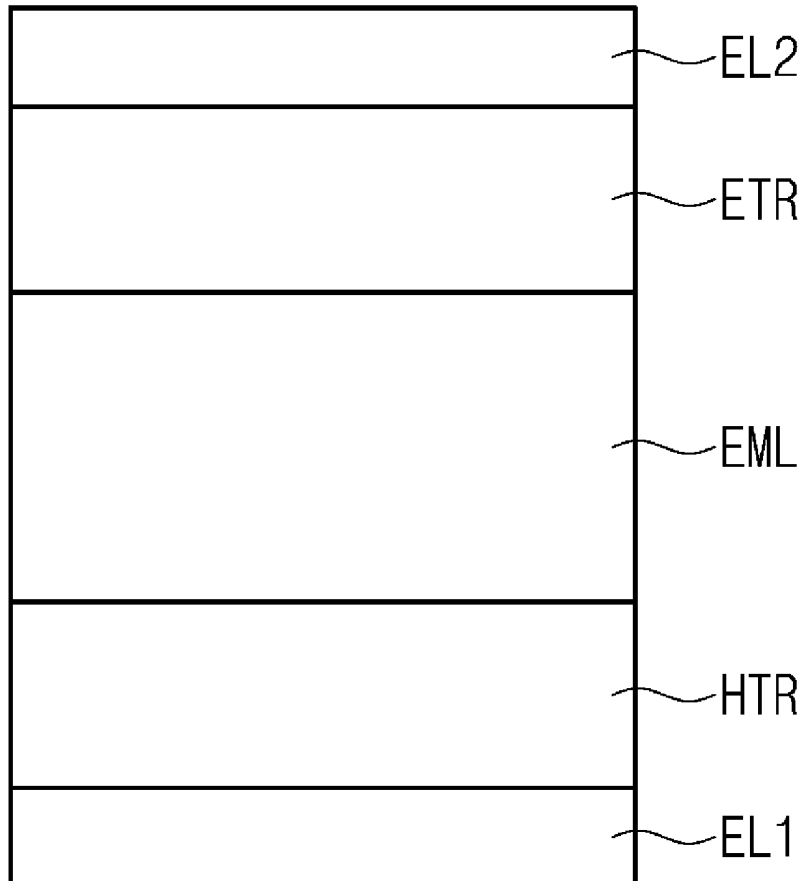

FIG. 1

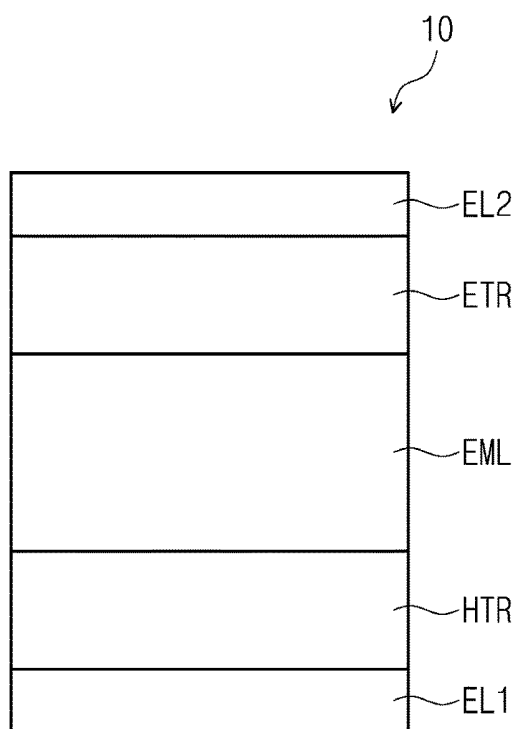

FIG. 2

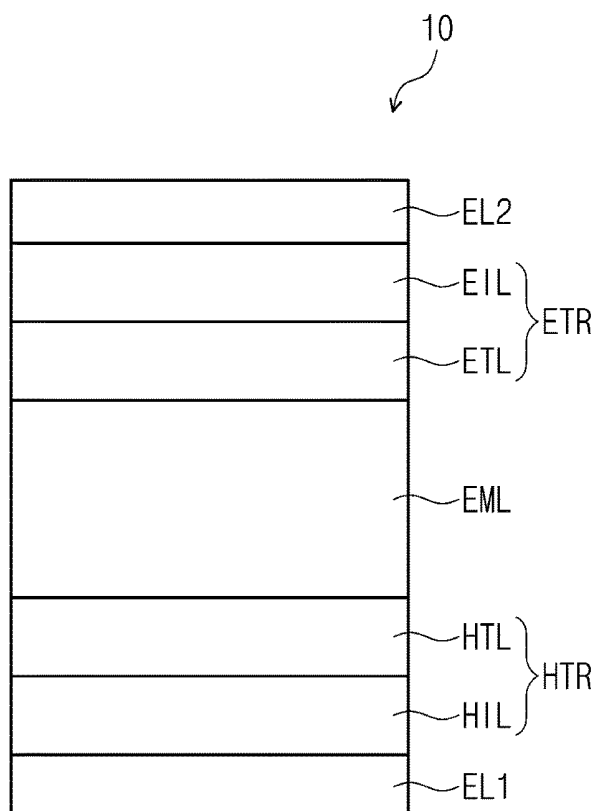
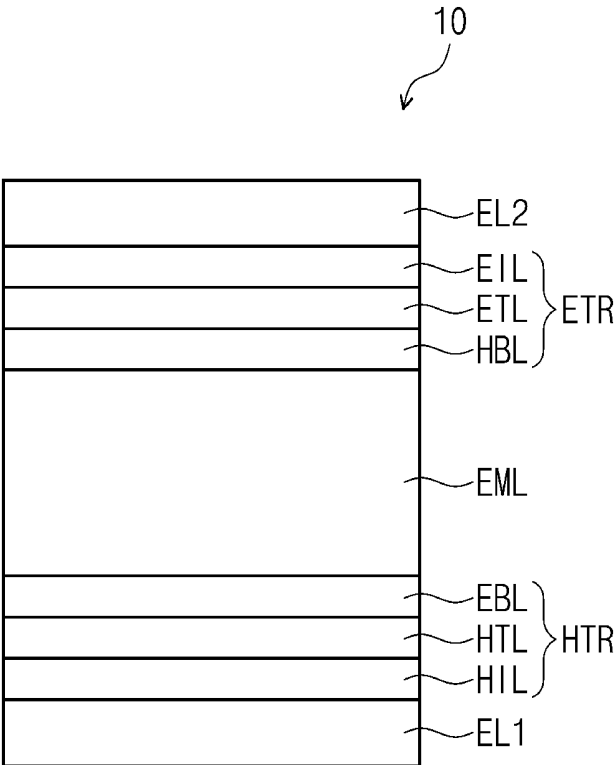

FIG. 3



**ORGANIC ELECTROLUMINESCENCE
DEVICE AND POLYCYCLIC COMPOUND
FOR ORGANIC ELECTROLUMINESCENCE
DEVICE**

CROSS-REFERENCE TO RELATED
APPLICATION

[0001] This application claims priority to and the benefit of Korean Patent Application No. 10-2018-0167210, filed on Dec. 21, 2018, the entire content of which is hereby incorporated by reference.

BACKGROUND

1. Field

[0002] The present disclosure herein relates to an organic electroluminescence device and a heterocyclic compound utilized therefor.

2. Description of the Related Art

[0003] The development of an organic electroluminescence display device as an image display device is being actively conducted. Unlike a liquid crystal display device, the organic electroluminescence display device is a so-called self-luminescent display device in which holes and electrons injected from a first electrode and a second electrode are recombined in an emission layer, and a light emission material, which is an organic compound included in the emission layer, emits light to realize a display (e.g., to show an image).

[0004] The organic electroluminescence device, for example, an organic device in the comparable art, includes: a first electrode; a hole transport layer disposed on the first electrode; an emission layer disposed on the hole transport layer; an electron transport layer disposed on the emission layer; and a second electrode disposed on the electron transport layer. Holes are injected from the first electrode, and the injected holes move through the hole transport layer and are injected into the emission layer. On the other hand, electrons are injected from the second electrode, and the injected electrons move through the electron transport layer and are injected into the emission layer. The holes and the electrons injected into the emission layer are recombined, thereby generating excitons in the emission layer. The organic electroluminescence device emits light generated when the excitons fall back (e.g., transition) to a ground state.

[0005] Recently, to realize an organic electroluminescence device having high efficiency, technology about phosphorescent luminescence (utilizing a triplet state energy) or a delayed fluorescent luminescence (utilizing triplet-triplet annihilation (TTA), which is a phenomenon of generating a singlet exciton by collision of triplet excitons) has been developed. For example, development of a thermally activated delayed fluorescence (TADF) material capable of generating a delayed fluorescence due to a small energy difference between singlet and triplet excitons and little overlap of the highest occupied molecular orbital (HOMO) and the lowest unoccupied molecular orbital (LUMO) is actively conducted.

SUMMARY

[0006] Aspects according to embodiments of the present disclosure are directed toward an organic electroluminescence device and a polycyclic compound utilized therefor.

[0007] According to an embodiment of the present disclosure, an organic electroluminescence device includes: a first electrode; a second electrode on the first electrode; and a plurality of organic layers between the first electrode and the second electrode, and including an emission layer.

[0008] The emission layer may include a polycyclic compound including an electron donor and an electron acceptor bonded to the electron donor. The electron donor may include (e.g., contain) an acridine derivative or a dibenzo-azasiline derivative, and the electron acceptor may include (e.g., contain) boron (B) as a ring-forming atom, oxygen (O) or sulfur (S) directly bonded to B, and a heterocyclic group in which three or five hexagonal rings are condensed.

[0009] The electron acceptor may include (e.g., contain) a dibenzo-thiaborinine derivative or a dibenzo-oxaborinine derivative.

[0010] The emission layer may include a host and a dopant, and the dopant may include the polycyclic compound in an embodiment. A difference (ΔE_{ST}) between a lowest singlet energy level and a lowest triplet energy level of the polycyclic compound in an embodiment may be 0.2 eV or less.

[0011] In an embodiment, the emission layer may emit light in a wavelength range of 440-500 nm.

[0012] The electron donor may be represented by Formula 1, and the electron acceptor may be represented by Formula 2-1 or Formula 2-2:

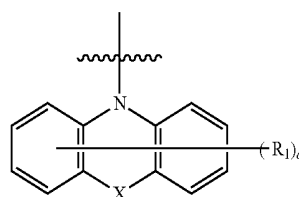

Formula 1

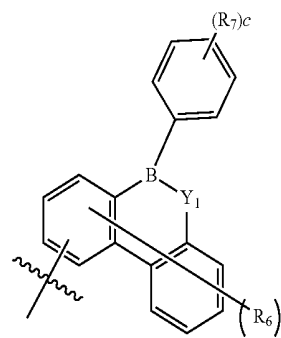

Formula 2-1

-continued

Formula 2-2

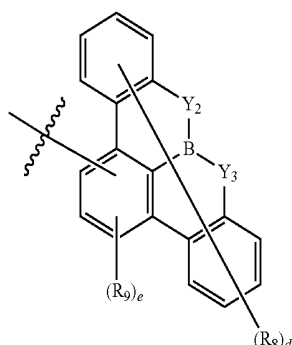

[0013] In Formula 1, R_1 may be a hydrogen atom, a deuterium atom, a halogen atom, a substituted or unsubstituted silyl group, a substituted or unsubstituted amine group, a substituted or unsubstituted alkoxy group having 1 to 10 carbon atoms, a substituted or unsubstituted alkyl group having 1 to 20 carbon atoms, a substituted or unsubstituted aryl group having 6 to 20 ring-forming carbon atoms, or a substituted or unsubstituted heteroaryl group having 3 to 20 ring-forming carbon atoms. a may be an integer of 0 to 8.

[0014] X may be CR_2R_3 or SiR_4R_5 . R_2 to R_5 may each independently be a hydrogen atom, a deuterium atom, a halogen atom, a substituted or unsubstituted alkyl group having 1 to 20 carbon atoms, a substituted or unsubstituted aryl group having 6 to 20 ring-forming carbon atoms, or a substituted or unsubstituted heteroaryl group having 3 to 20 ring-forming carbon atoms, or may be bonded to one or more adjacent groups to form a ring.

[0015] In one embodiment, R_1 may be a hydrogen atom, a fluorine atom, a methyl group, a t-butyl group, a substituted or unsubstituted arylamine group having 6 to 20 ring-forming carbon atoms, a substituted or unsubstituted phenyl group, a substituted or unsubstituted phenanthryl group, a substituted or unsubstituted thiophenyl group, a substituted or unsubstituted carbazolyl group, or a substituted or unsubstituted acridinyl group.

[0016] R_2 to R_5 may each independently be a methyl group or a substituted or unsubstituted phenyl group, or may be bonded to one or more adjacent groups to form a dibenzospiro ring.

[0017] In Formula 2-1 and Formula 2-2, Y_1 to Y_3 may each independently be O or S. In one embodiment, Y_2 and Y_3 may be the same. R_6 to R_9 may each independently be a hydrogen atom, a deuterium atom, a halogen atom, a substituted or unsubstituted alkoxy group having 1 to 10 carbon atoms, a substituted or unsubstituted sulfide group having 1 to 10 carbon atoms, a substituted or unsubstituted amine group, a substituted or unsubstituted silyl group, a substituted or unsubstituted alkyl group having 1 to 20 carbon atoms, a substituted or unsubstituted aryl group having 6 to 20 ring-forming carbon atoms, or a substituted or unsubstituted heteroaryl group having 3 to 20 ring-forming carbon atoms. b may be an integer of 0 to 7, c may be an integer of 0 to 5, d may be an integer of 0 to 8, and e may be an integer of 0 to 2.

[0018] In an embodiment, the polycyclic compound may be represented by Formula 3-1 or Formula 3-2:

Formula 3-1

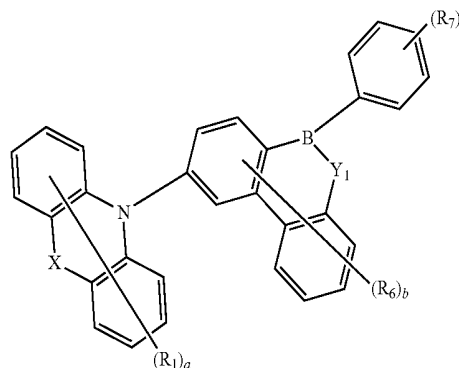

Formula 3-2

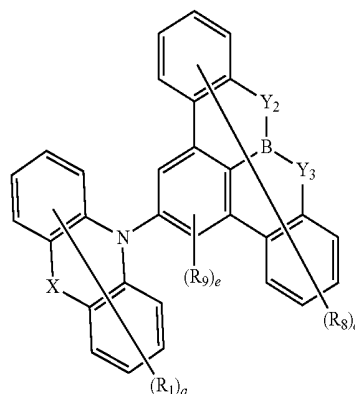

[0019] In Formula 3-1 and Formula 3-2, R_1 , X, Y_1 to Y_3 , R_6 to R_9 , and a to e may be the same as respectively defined in connection with Formula 1, Formula 2-1, and Formula 2-2.

[0020] The electron donor represented by Formula 1 may be represented by Formula 4:

Formula 4

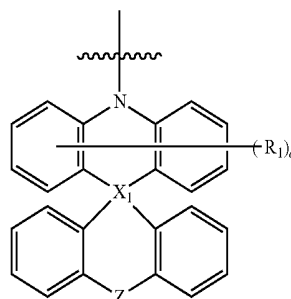

[0021] In Formula 4, X_1 may be C or Si. Z may be a direct bond, O, or S. R_1 and a may be the same as respectively defined in connection with Formula 1.

[0022] In an embodiment of the present disclosure, an organic electroluminescence device includes: a first electrode; a second electrode on the first electrode; and a plurality of organic layers between the first electrode and the second electrode, and may include an emission layer.

[0023] At least one organic layer of the plurality of organic layers may include a polycyclic compound represented by Formula A:

DU-AU

Formula A

[0024] In Formula A, DU may be represented by Formula 1 described above, and AU may be represented by Formula 2-1 or Formula 2-2 described above.

[0025] In an embodiment of the present disclosure, a polycyclic compound includes: an electron donor represented by Formula 1 described above; and an electron acceptor bonded to the electron donor and represented by Formula 2-1 or Formula 2-2 described above.

[0026] In an embodiment of the present disclosure, a polycyclic compound is represented by Formula A described above.

BRIEF DESCRIPTION OF THE FIGURES

[0027] The accompanying drawings are included to provide a further understanding of the subject matter of the present disclosure, and are incorporated in and constitute a part of this specification. The drawings illustrate exemplary embodiments of the present disclosure and, together with the description, serve to explain principles of the present disclosure. In the drawings:

[0028] FIG. 1 is a cross-sectional view schematically illustrating an organic electroluminescence device according to an embodiment of the present disclosure;

[0029] FIG. 2 is a cross-sectional view schematically illustrating an organic electroluminescence device according to an embodiment of the present disclosure; and

[0030] FIG. 3 is a cross-sectional view schematically illustrating an organic electroluminescence device according to an embodiment of the present disclosure.

DETAILED DESCRIPTION

[0031] The subject matter of the present disclosure may have various modifications and may be embodied in different forms, and example embodiments will be explained in more detail with reference to the accompanying drawings. The subject matter of the present disclosure may, however, be embodied in different forms and should not be construed as limited to the embodiments set forth herein. Rather, all modifications, equivalents, and substituents which are included in the spirit and technical scope of the present disclosure should be included in the present disclosure.

[0032] Like reference numerals refer to like elements throughout. In the drawings, the dimensions of structures are exaggerated for clarity of illustration. It will be understood that, although the terms “first,” “second,” etc., may be used herein to describe various elements, these elements should not be limited by these terms. These terms are only used to distinguish one element from another element. Thus, a first element could be termed a second element without departing from the teachings of the present disclosure. Similarly, a second element could be termed a first element. As used herein, the singular forms are intended to include the plural forms as well, unless the context clearly indicates otherwise.

[0033] In the description, it should be understood that the term “comprise” or “have” are intended to specify the presence of the stated features, numerals, steps, operations, elements, parts, or combinations thereof, but do not exclude

the possibility of the presence or addition of one or more other features, numerals, steps, operations, elements, parts, or combinations thereof.

[0034] In the description, when a layer, a film, a region, a plate, etc., is referred to as being “on” or “above” another part, it can be “directly on” the other part, or intervening layers may also be present. Similarly, when a layer, a film, a region, a plate, etc., is referred to as being “under” or “below” another part, it can be “directly under” the other part, or intervening layers may also be present. Additionally, the term “disposed on” in the description may include the case where it is disposed on the lower part as well as on the upper part.

[0035] FIG. 1 is a cross-sectional view schematically illustrating an organic electroluminescence device according to an embodiment of the present disclosure. The organic electroluminescence device 10 according to the embodiment may include a first electrode EL1, a hole transport region HTR, an emission layer EML, an electron transport region ETR, and a second electrode EL2, which are sequentially laminated (e.g., stacked).

[0036] Compared with FIG. 1, FIG. 2 illustrates a cross-sectional view of an organic electroluminescence device 10 according to an embodiment, in which a hole transport region HTR includes a hole injection layer HIL and a hole transport layer HTL, and an electron transport region ETR includes an electron injection layer EIL and an electron transport layer ETL. In addition, compared with FIG. 1, FIG. 3 illustrates a cross-sectional view of an organic electroluminescence device 10 according to an embodiment, in which a hole transport region HTR includes a hole injection layer HIL, a hole transport layer HTL and an electron blocking layer EBL, and an electron transport region ETR includes an electron injection layer EIL, an electron transport layer ETL and a hole blocking layer HBL.

[0037] The first electrode EL1 may have conductivity (e.g., electrical conductivity). The first electrode EL1 may be formed of a metal, a metal alloy and/or a conductive compound. The first electrode EL1 may be an anode. In addition, the first electrode EL1 may be a pixel electrode. The first electrode EL1 may be a transmissive electrode, a transmissive electrode, or a reflective electrode. When the first electrode EL1 is a transmissive electrode, the first electrode EL1 may include a transparent metal oxide, for example, indium tin oxide (ITO), indium zinc oxide (IZO), zinc oxide (ZnO), indium tin zinc oxide (ITZO), etc. When the first electrode EL1 is a transmissive electrode or a reflective electrode, the first electrode EL1 may include Ag, Mg, Cu, Al, Pt, Pd, Au, Ni, Nd, Ir, Cr, Li, Ca, LiF/Ca, LiF/Al, Mo, Ti, or a compound or a mixture thereof (for example, a mixture of Ag and Mg). In some embodiments, the first electrode EL1 may have a structure which has a plurality of layers including a reflective layer or a transmissive layer formed of any of the above described materials; and a transparent conductive layer formed of ITO, IZO, ZnO, ITZO, etc. For example, the first electrode EL1 may have a three-layered structure of ITO/Ag/ITO, but embodiments of the present disclosure are not limited thereto. A thickness of the first electrode EL1 may be about 1000-10000 Å, for example, about 1000-3000 Å.

[0038] The hole transport region HTR may be disposed on the first electrode EL1. The hole transport region HTR may

include a hole injection layer HIL, a hole transport layer HTL, a hole buffer layer, and/or an electron blocking layer EBL.

[0039] The hole transport region HTR may have a structure of: a single layer formed of a single material; a single layer formed of a plurality of different materials; or a multi-layer having a plurality of layers formed of a plurality of different materials.

[0040] For example, the hole transport region HTR may have a structure of a single layer which is a hole injection layer HIL or a hole transport layer HTL, or may have a structure of a single layer formed of a hole injection material and a hole transport material. In some embodiments, the hole transport region HTR may have a structure of a single layer formed of a plurality of different materials, or may have a structure of, sequentially laminated from the first electrode EL1, hole injection layer HIL/hole transport layer HTL, hole injection layer HIL/hole transport layer HTL/hole buffer layer, hole injection layer HIL/hole buffer layer, hole transport layer HTL/hole buffer layer, or hole injection layer HIL/hole transport layer HTL/electron blocking layer EBL, but embodiments of the present disclosure are not limited thereto.

[0041] The hole transport region HTR may be formed by utilizing various suitable methods such as a vacuum deposition method, a spin coating method, a casting method, a Langmuir-Blodgett (LB) method, an inkjet printing method, a laser printing method, and/or a laser induced thermal imaging (LITI) method.

[0042] The hole injection layer HIL may include, for example, a phthalocyanine compound (such as copper phthalocyanine), N,N'-diphenyl-N,N'-bis-[4-(phenyl-m-tolyl-amino)-phenyl]-biphenyl-4,4'-diamine (DNTPD), 4,4',4''-tris(3-methylphenylphenylamino)triphenylamine (m-MTDATA), 4,4',4''-tris(N,N-diphenylamino)triphenylamine (TDATA), 4,4',4''-tris[2-naphthyl(phenyl)amino]triphenylamine (2-TNATA), poly(3,4-ethylenedioxythiophene)/poly(4-styrenesulfonate) (PEDOT/PSS), polyaniline/dodecylbenzenesulfonic acid (PANI/DBSA), polyaniline/camphorsulfonic acid (PANI/CSA), polyaniline/poly(4-styrenesulfonate) (PANI/PSS), N,N'-di(1-naphthyl)-N,N'-diphenylbenzidine (NPB), triphenylamine-containing polyetherketone (TPAPEK), 4-isopropyl-4'-methyldiphenyliodoniumtetrakis(pentafluorophenyl)borate, dipyrzino[2,3-f:2',3'-h]quinoxaline-2,3,6,7,10,11-hexacarbonitrile (HAT-CN), etc.

[0043] The hole transport layer HTL may further include, for example, a carbazole-based derivative (such as N-phenylcarbazole and/or polyvinylcarbazole), a fluorine-based derivative, a triphenylamine-based derivative (such as N,N'-bis(3-methylphenyl)-N,N'-diphenyl-(1,1-biphenyl)-4,4'-diamine (TPD) and/or 4,4',4''-tris(N-carbazolyl)triphenylamine (TCTA)), N,N'-di(1-naphthyl)-N,N'-diphenylbenzidine (NPB), 4,4'-cyclohexylidenebis[N,N-bis(4-methylphenyl)benzenamine] (TAPC), 4,4'-bis[N,N'-(3-tolyl)amino]-3,3'-dimethylbiphenyl (HMTPD), 1,3-bis(N-carbazolyl)benzene (mCP), etc.

[0044] A thickness of the hole transport region HTR may be about 100-10000 Å, for example, about 100-5000 Å. A thickness of the hole injection layer HIL may be, for example, about 30-1000 Å, and a thickness of the hole transport layer HTL may be about 10-1000 Å. For example, a thickness of the electron blocking layer EBL may be about 10-1000 Å. When the thicknesses of the hole transport

region HTR, the hole injection layer HIL, the hole transport layer HTL and the electron blocking layer EBL satisfy the above described ranges, suitable or satisfactory hole transport performance may be achieved without substantial rise of a driving voltage.

[0045] The hole transport region HTR may further include a charge generating material in addition to the above described materials to improve conductivity. The charge generating material may be uniformly or non-uniformly dispersed in the hole transport region HTR. The charge generating material may be, for example, a p-dopant. The p-dopant may be a quinone derivative, a metal oxide, and/or a cyano group-containing compound, but embodiments of the present disclosure are not limited thereto. Non-limited examples of the p-dopant may be, for example, a quinone derivative (such as tetracyanoquinodimethane (TCNQ) and/or 2,3,5,6-tetrafluoro-tetracyanoquinodimethane (F4-TCNQ)), a metal oxide (such as a tungsten oxide and/or a molybdenum oxide), etc., but embodiments of the present disclosure are not limited thereto.

[0046] As described, the hole transport region HTR may further include the hole buffer layer and/or the electron blocking layer EBL in addition to the hole injection layer HIL and the hole transport layer HTL. The hole buffer layer may improve the light emission efficiency by compensating a resonance distance according to the wavelength of the light emitted from the emission layer EML. The materials included in the hole transport region HTR may also be utilized as materials included in the hole buffer layer. The electron blocking layer EBL may be a layer which prevents or reduces electron injection from the electron transport region ETR to the hole transport region HTR.

[0047] The emission layer EML may be disposed on the hole transport region HTR. The emission layer EML may have a thickness of, for example, about 100-1000 Å or about 100-300 Å. The emission layer EML may have a structure of: a single layer formed of a single material; a single layer formed of a plurality of different materials; or a multi-layer having a plurality of layers formed of a plurality of different materials.

[0048] The emission layer may include a polycyclic compound including an electron donor and an electron acceptor which is bonded to the electron donor. The electron donor may contain an acridine derivative or a dibenzo-azasiline derivative. The electron acceptor may contain B as a ring-forming atom, and O or S directly bonded to B, and may have a heterocyclic group in which three or five hexagonal rings are condensed.

[0049] A nitrogen atom of the acridine derivative or a dibenzo-azasiline derivative may be bonded to the electron acceptor.

[0050] When the electron acceptor is a heterocyclic group in which three hexagonal rings are condensed, the electron acceptor may have one aliphatic hetero-hexagonal ring group containing B, and O or S directly bonded to B, and two substituted or unsubstituted benzene ring groups condensed to the aliphatic hetero-hexagonal ring group.

[0051] When the electron acceptor is a heterocyclic group in which five hexagonal rings are condensed, the electron acceptor may have a naphthyl skeleton (e.g., a naphthalene-like skeleton, e.g., a skeleton with two fused hexagonal rings) containing B, and two O or S bonds directly bonded to B, and three substituted or unsubstituted benzene ring groups condensed to the naphthyl skeleton.

[0052] The electron acceptor may contain, for example, a dibenzo-thiaborinine derivative or a dibenzo-oxaborinine derivative.

[0053] In the description, the term “substituted or unsubstituted” refers to an unsubstituted functional group or a functional group substituted with at least one substituent selected from the group consisting of a deuterium atom, a halogen atom, a cyano group, a silyl group, an oxy group, a thio group, an alkyl group, an alkoxy group, a hydrocarbon ring group, an aryl group, and a heterocyclic group. In addition, each of the substituents exemplified above may be substituted or unsubstituted. For example, a biphenyl group may be interpreted as an aryl group or a phenyl group substituted with a phenyl group.

[0054] In the description, the expression “forming a ring via the combination with an adjacent group” may refer to forming a substituted or unsubstituted hydrocarbon ring, or a substituted or unsubstituted heterocycle via the combination with an adjacent group. The hydrocarbon ring includes an aliphatic hydrocarbon ring and an aromatic hydrocarbon ring. The heterocycle includes an aliphatic heterocycle and an aromatic heterocycle. The ring formed by the combination with an adjacent group may be a monocyclic ring or a polycyclic ring. In addition, the ring formed via the combination with each other (e.g., with an adjacent group) may be combined with another ring to form a spiro structure.

[0055] In the description, the term “adjacent group” may refer to a substituent substituted for an atom which is directly combined with (e.g., directly linked to) an atom substituted with a corresponding substituent, another substituent substituted for an atom which is substituted with a corresponding substituent, or a substituent sterically positioned at the nearest position to a corresponding substituent. For example, in 1,2-dimethylbenzene, the two methyl groups may be interpreted as “adjacent groups” to each other, and in 1,1-diethylcyclopentene, the two ethyl groups may be interpreted as “adjacent groups” to each other.

[0056] In the description, the halogen atom may be, for example, a fluorine atom, a chlorine atom, a bromine atom and/or an iodine atom.

[0057] In the description, the alkyl group may be a linear, branched or cyclic alkyl group. The carbon number (e.g., number of carbon atoms) of the alkyl group may be 1 to 50, 1 to 30, 1 to 20, 1 to 10, or 1 to 6. Examples of the alkyl group may include a methyl group, an ethyl group, an n-propyl group, an isopropyl group, an n-butyl group, an s-butyl group, a t-butyl group, an i-butyl group, a 2-ethylbutyl group, a 3,3-dimethylbutyl group, an n-pentyl group, an i-pentyl group, a neopentyl group, a t-pentyl group, a cyclopentyl group, a 1-methylpentyl group, a 3-methylpentyl group, a 2-ethylpentyl group, a 4-methyl-2-pentyl group, an n-hexyl group, a 1-methylhexyl group, a 2-ethylhexyl group, a 2-butylhexyl group, a cyclohexyl group, a 4-methylcyclohexyl group, a 4-t-butylcyclohexyl group, an n-heptyl group, a 1-methylheptyl group, a 2,2-dimethylheptyl group, a 2-ethylheptyl group, a 2-butylheptyl group, an n-octyl group, a t-octyl group, a 2-ethyloctyl group, a 2-butyloctyl group, a 2-hexyloctyl group, a 3,7-dimethyloctyl group, a cyclooctyl group, an n-nonyl group, an n-decyl group, an adamantyl group, a 2-ethyldecyl group, a 2-butyldecyl group, a 2-hexyldecyl group, a 2-octyldecyl group, an n-undecyl group, an n-dodecyl group, a 2-ethyl-dodecyl group, a 2-butyl-dodecyl group, a 2-hexyl-dodecyl group, a 2-octyl-dodecyl group, an n-tridecyl group, an n-tetradecyl

group, an n-pentadecyl group, an n-hexadecyl group, a 2-ethylhexadecyl group, a 2-butylhexadecyl group, a 2-hexylhexadecyl group, a 2-octylhexadecyl group, an n-heptadecyl group, an n-octadecyl group, an n-nonadecyl group, an n-eicosyl group, a 2-ethyleicosyl group, a 2-butyleicosyl group, a 2-hexyleicosyl group, a 2-octyleicosyl group, an n-henicosyl group, an n-docosyl group, an n-tricosyl group, an n-tetracosyl group, an n-pentacosyl group, an n-hexacosyl group, an n-heptacosyl group, an n-octacosyl group, an n-nonacosyl group, an n-triacontyl group, etc., but embodiments of the present disclosure are not limited thereto.

[0058] In the description, the methyl group may be represented by Me. In the description, MeO may represent, for example, a methoxy group.

[0059] In the description, the hydrocarbon ring group refers to an optional functional group or substituent derived from an aliphatic hydrocarbon ring. The hydrocarbon ring group may be a saturated hydrocarbon ring group having 5-20 ring-forming carbon atoms.

[0060] In the description, the aryl group refers to an optional functional group or substituent derived from an aromatic hydrocarbon ring. The aryl group may be a monocyclic aryl group or a polycyclic aryl group. The number of ring-forming carbon atoms in the aryl group may be 6 to 30, 6 to 20, or 6 to 15. Examples of the aryl group may include a phenyl group, a naphthyl group, a fluorenyl group, an anthracenyl group, a phenanthryl group, a biphenyl group, a terphenyl group, a quaterphenyl group, a quinquephenyl group, a sexiphenyl group, a triphenylenyl group, a pyrenyl group, a benzofluoranthenyl group, a chrysenyl group, etc., but embodiments of the present disclosure are not limited thereto.

[0061] In the description, the fluorenyl group may be substituted, and two substituents may be combined with each other to form a spiro structure. Examples of a substituted fluorenyl group are as follows. However, embodiments of the present disclosure are not limited thereto.

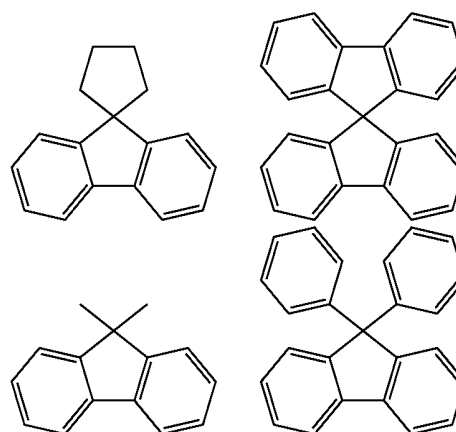

[0062] In the description, the heteroaryl group may be a heteroaryl group including O, N, P, Si, and/or S as a heteroatom. When the heteroaryl group includes at least two hetero atoms, the at least two hetero atoms may be the same as or different from each other. The heteroaryl group may be a monocyclic heteroaryl group or polycyclic heteroaryl group. The number of ring-forming carbon atoms in the heteroaryl group may be 2 to 30, 2 to 20, or 2 to 10. Examples of the heteroaryl group may include a thiophene

group, a furan group, a pyrrole group, an imidazole group, a thiazole group, an oxazole group, an oxadiazole group, a triazole group, a pyridine group, a bipyridine group, a pyrimidine group, a triazine group, a triazole group, an acridyl group, a pyridazine group, a pyrazinyl group, a quinoline group, a quinazoline group, a quinoxaline group, a phenoxazine group, a phthalazine group, a pyrido pyrimidine group, a pyrido pyrazine group, a pyrazino pyrazine group, an isoquinoline group, an indole group, a carbazole group, an N-arylcarbazole group, an N-heteroarylcarbazole group, an N-alkylcarbazole group, a benzoxazole group, a benzimidazole group, a benzothiazole group, a benzocarbazole group, a benzothiophene group, a dibenzothiophene group, a thienothiophene group, a benzofuran group, a phenanthroline group, a thiazole group, an isooxazole, an oxadiazole group, a thiadiazole group, a phenothiazine group, a dibenzosilole group, a dibenzofuran group, etc., but embodiments of the present disclosure are not limited thereto.

[0063] In the description, the silyl group may include an alkylsilyl group and an arylsilyl group. Examples of the silyl group may include a trimethylsilyl group, a triethylsilyl group, a t-butyl dimethylsilyl group, a vinyl dimethylsilyl group, a propyl dimethylsilyl group, a triphenylsilyl group, a diphenylsilyl group, a phenylsilyl group, etc., but embodiments of the present disclosure are not limited thereto.

[0064] In the description, the thio group may include an alkylthio group and an arylthio group.

[0065] In the description, the oxy group may include an alkoxy group and an aryloxy group. The alkoxy group may be a linear, branched or cyclic chain. The carbon number of the alkoxy group is not particularly limited, but may be, for example, 1 to 20 or 1 to 10. Examples of the oxy group may include methoxy, ethoxy, n-propoxy, isopropoxy, butoxy, pentyloxy, hexyloxy, octyloxy, nonyloxy, decyloxy, benzyloxy, etc., but embodiments of the present disclosure are not limited thereto.

[0066] In the description, the carbon number of the amine group is not particularly limited, but may be 1 to 30. The amine group may include an alkylamine group and an arylamine group. Examples of the amine group may include a methylamine group, a dimethylamine group, a phenylamine group, a diphenylamine group, a naphthylamine group, a 9-methyl-anthracenylamine group, a triphenylamine group, etc., but embodiments of the present disclosure are not limited thereto.

[0067] In the description, the alkyl groups in the alkylaryl group, the alkylheteroaryl group, the silyl group, and the alkylamine group are the same as the alkyl group described above.

[0068] In the description, the aryl groups in the aryloxy group, the arylsilyl group, and the arylamine group are the same as the aryl group described above.

[0069] In the description, the term “direct linkaae” may refer to a single bond.

[0070] Meanwhile, in the description, “

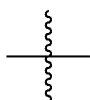

” represents a connecting position.

[0071] A polycyclic compound of an embodiment may be represented by Formula A:

DU-AU

Formula A

[0072] In Formula A, DU may be an electron donor represented by Formula 1, and

[0073] AU may be an electron acceptor represented by Formula 2-1 or Formula 2-2.

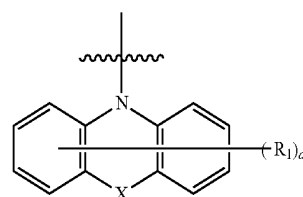

Formula 1

Formula 2-1]

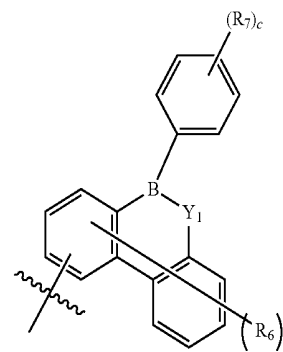

Formula 2-2

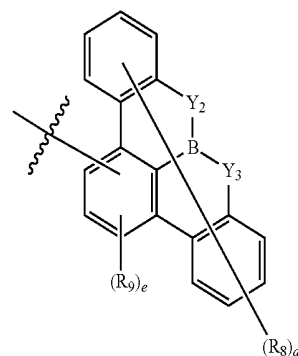

[0074] In Formula 1, R_1 may be a hydrogen atom, a deuterium atom, a halogen atom, a silyl group, an amine group, an alkoxy group, an alkyl group, an aryl group, or a heteroaryl group. The silyl group may be a substituted or unsubstituted silyl group, the amine group may be a substituted or unsubstituted amine group, the alkoxy group may be a substituted or unsubstituted alkoxy group having 1 to 10 carbon atoms, and the alkyl group may be a substituted or unsubstituted alkyl group having 1 to 20 carbon atoms. The aryl group may be a substituted or unsubstituted aryl group having 6 to 20 ring-forming carbon atoms, and the heteroaryl group may be a substituted or unsubstituted heteroaryl group having 3 to 20 ring-forming carbon atoms.

[0075] For example, R_1 may be a hydrogen atom, a fluorine atom, a methyl group, a t-butyl group, a substituted or unsubstituted arylamine group having 6 to 20 ring-forming carbon atoms, a substituted or unsubstituted phenyl group, a substituted or unsubstituted phenanthryl group, a substituted

or unsubstituted thiophenyl group, a substituted or unsubstituted carbazolyl group, or a substituted or unsubstituted acridinyl group.

[0076] a may be an integer of 0 to 8. a may be, for example, 1 or 2. When a is 1, R_1 may not be a hydrogen atom. For example, when a is 1, R_1 may be a heteroaryl group. When a is 2 or larger, a plurality of R_1 s may be the same as or different from each other.

[0077] X may be CR_2R_3 or SiR_4R_5 .

[0078] R_2 to R_5 may each independently be a hydrogen atom, a deuterium atom, a halogen atom, an alkyl group, an aryl group, or a heteroaryl group, or may be bonded to adjacent groups to form a ring. The alkyl group is a substituted or unsubstituted alkyl group having 1 to 20 carbon atoms, the aryl group is a substituted or unsubstituted aryl group having 6 to 20 ring-forming carbon atoms, and the heteroaryl group is a substituted or unsubstituted heteroaryl group having 3 to 20 ring-forming carbon atoms. For example, R_2 to R_5 may each independently be a methyl group or a substituted or unsubstituted phenyl group, or may be connected to each other to form a dibenzospiro ring. When R_2 to R_5 are bonded to one or more adjacent groups to form a ring, the dibenzospiro ring may be formed. The dibenzospiro ring may be a substituted or unsubstituted aryl group, or a substituted or unsubstituted heteroaryl group.

[0079] R_2 to R_5 may be the same as or different from each other. For example, R_2 to R_5 may be the same as each other. In some embodiments, R_2 to R_5 may be bonded to adjacent groups to form a spiro ring having a symmetrical structure.

[0080] In Formula 2-1 and Formula 2-2, Y_1 to Y_3 may each independently be O or S. Y_2 and Y_3 may be the same as or different from each other. For example, Y_2 and Y_3 may be the same atom.

[0081] R_6 to R_9 may each independently be a hydrogen atom, a deuterium atom, a halogen atom, an alkoxy group, a sulfide group, an amine group, a silyl group, an alkyl group, an aryl group, or a heteroaryl group. The alkoxy group may be a substituted or unsubstituted alkoxy group having 1 to 10 carbon atoms, the sulfide group may be a substituted or unsubstituted sulfide group having 1 to 10 carbon atoms, the amine group may be a substituted or unsubstituted amine group, and the silyl group may be a substituted or unsubstituted silyl group. The alkyl group may be a substituted or unsubstituted alkyl group having 1 to 20 carbon atoms, the aryl group may be a substituted or unsubstituted aryl group having 6 to 20 ring-forming carbon atoms, and the heteroaryl group may be a substituted or unsubstituted heteroaryl group having 3 to 20 ring-forming carbon atoms. The substituted aryl group may be an aryl group substituted with an aryloxy group having 1 to 20 carbon atoms or substituted with an arylsulfide group having 1 to 20 carbon atoms.

[0082] For example, R_6 to R_9 may each independently be a methyl group, an isopropyl group, an n-hexyl group, a fluorine atom, a substituted or unsubstituted arylsilyl group having 6 to 20 carbon atoms, a substituted or unsubstituted alkoxy group having 1 to 10 carbon atoms, a substituted or unsubstituted phenyl group, a substituted or unsubstituted pyridine group, a substituted or unsubstituted pyrimidine group, or a substituted or unsubstituted acridinyl group.

[0083] b may be an integer of 0 to 7, c may be an integer of 0 to 5, d may be an integer of 0 to 8, and e may be an

integer of 0 to 2. For example, b may be 0 or 1, and d may be 0, 1, or 2. When each of b to e is 1, each of R_6 to R_9 may not be a hydrogen atom.

[0084] A polycyclic compound of an embodiment may be represented by Formula 3-1 or Formula 3-2:

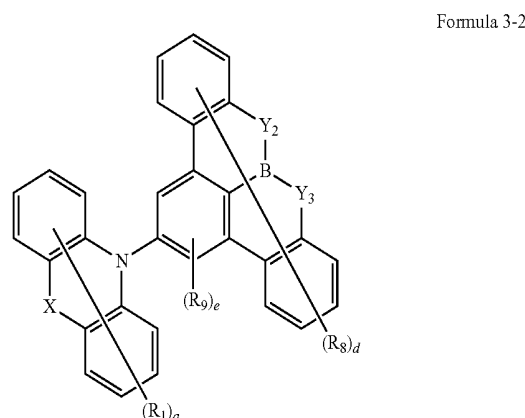
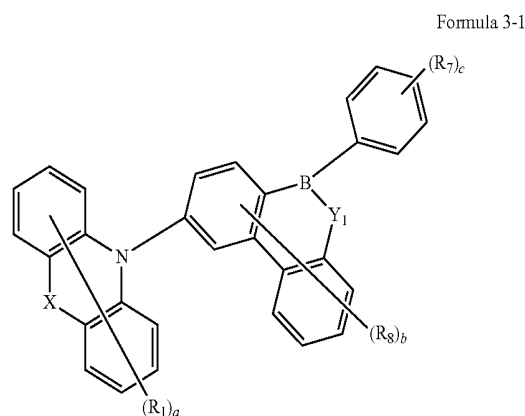

[0085] Formula 3-1 and Formula 3-2 are example (e.g., specified) Formulae embodying substitution positions of the electron donor and the electron acceptor in the polycyclic compound of an embodiment. In Formula 3-1 and Formula 3-2, R_1 , X , Y_1 to Y_3 , R_6 to R_9 , and a to e may be the same as respectively defined in connection with Formula 1, Formula 2-1, and Formula 2-2.

[0086] The electron donor represented by Formula 1 may be represented by Formula 4:

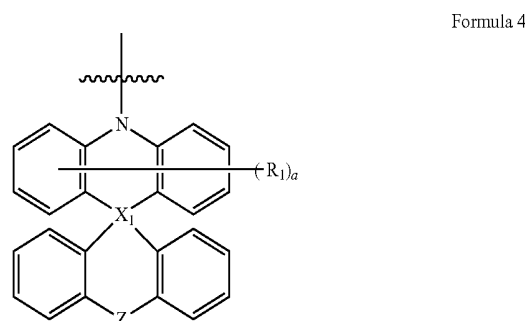

[0087] Formula 4 is an example (e.g., a specified) Formula embodying a structure in which R_2 to R_5 in Formula 1 adjacent to each other (e.g., R_2 and R_3 , or R_4 and R_5) are bonded to form a spiro ring.

[0088] In Formula 4, X_1 may be C or Si, and Z may be a direct bond, O, or S. R_1 and a may be the same as respectively defined in connection with Formula 1.

[0089] The electron donor represented by Formula 1 may be represented by Formula 5:

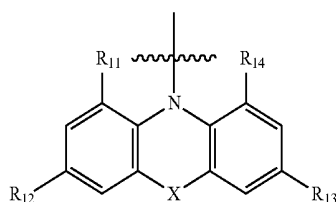

Formula 5

[0090] Formula 5 is an example (e.g., a specified) Formula embodying a substitution position of R_1 in Formula 1. For example, R_1 may be substituted to at least one position of an ortho position or a para position with respect to N.

[0091] R_{11} to R_{14} may be a hydrogen atom, a deuterium atom, a halogen atom, a silyl group, an amine group, an alkoxy group, an alkyl group, an aryl group, or a heteroaryl group. The silyl group may be a substituted or unsubstituted silyl group, the amine group may be a substituted or unsubstituted amine group, the alkoxy group may be a substituted or unsubstituted alkoxy group having 1 to 10 carbon atoms, and the alkyl group may be a substituted or unsubstituted alkyl group having 1 to 20 carbon atoms. The aryl group may be a substituted or unsubstituted aryl group having 6 to 20 ring-forming carbon atoms, and the heteroaryl group may be a substituted or unsubstituted heteroaryl group having 3 to 20 ring-forming carbon atoms.

[0092] For example, R_{11} to R_{14} may each independently be a hydrogen atom, a fluorine atom, a methyl group, a t-butyl group, a substituted or unsubstituted arylamine group having 6 to 20 ring-forming carbon atoms, a substituted or unsubstituted phenyl group, a substituted or unsubstituted phenanthryl group, a substituted or unsubstituted thiophenyl group, a substituted or unsubstituted carbazolyl group, or a substituted or unsubstituted acridinyl group. At least one of R_{11} to R_{14} may not be hydrogen. X may be the same as defined in connection with Formula 1.

[0093] The electron acceptor represented by Formula 2-2 may be represented by the following Formulae 5-1 or 5-2.

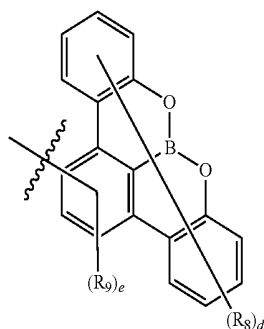

Formula 5-1

-continued

Formula 5-2

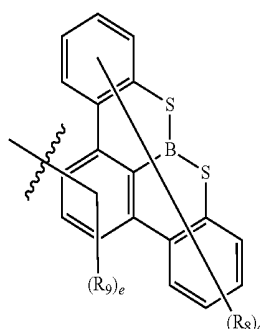

[0094] In Formula 5-1 and Formula 5-2, R_9 , R_8 , d, and e may be the same as respectively defined in connection with Formula 2-2.

[0095] The electron acceptor represented by Formula 2-1 may be represented by Formula 6-1, and the electron acceptor represented by Formula 2-2 may be represented by Formula 6-2:

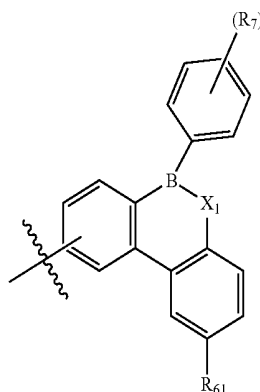

Formula 6-1

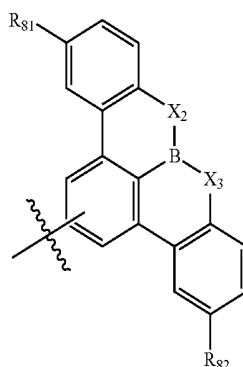

Formula 6-2

[0096] Formula 6-1 is an example (e.g., a specified) Formula embodying the number and substitution position of R_6 in Formula 2-1, and Formula 6-2 is an example (e.g., a specified) Formula embodying the number and substitution position of R_8 in Formula 2-2.

[0097] For example, Formula 6-1 is an example (e.g., a specified) Formula embodying that, in Formula 2-1, R_6 is substituted at the para position with respect to X_1 , and Formula 6-2 is an example (e.g., a specified) Formula

embodying that, in Formula 2-2, all R_9 s are hydrogen atoms and R_8 is substituted at the para position with respect to X_2 or X_3 .

[0098] R_{61} , R_{81} , and R_{82} may each independently be a hydrogen atom, a deuterium atom, a halogen atom, an alkoxy group, a sulfide group, an amine group, a silyl group, an alkyl group, an aryl group, or a heteroaryl group. The alkoxy group may be a substituted or unsubstituted alkoxy group having 1 to 10 carbon atoms, the sulfide group may be a substituted or unsubstituted sulfide group having 1 to 10 carbon atoms, the amine group may be a substituted or unsubstituted amine group, and the silyl group may be a substituted or unsubstituted silyl group. The alkyl group may be a substituted or unsubstituted alkyl group having 1 to 20 carbon atoms, the aryl group may be a substituted or unsubstituted aryl group having 6 to 20 ring-forming carbon atoms, and the heteroaryl group may be a substituted or unsubstituted heteroaryl group having 3 to 20 ring-forming carbon atoms. The substituted aryl group may be an aryl group substituted with an aryloxy group having 1 to 20 carbon atoms or substituted with an arylsulfide group having 1 to 20 carbon atoms.

[0099] For example, R_{61} , R_{81} , and R_{82} may each independently be a methyl group, an isopropyl group, an n-hexyl group, a fluorine atom, a substituted or unsubstituted aryl-silyl group having 6 to 20 carbon atoms, a substituted or unsubstituted alkoxy group having 1 to 10 carbon atoms, a substituted or unsubstituted phenyl group, a substituted or unsubstituted pyridine group, a substituted or unsubstituted pyrimidine group, or a substituted or unsubstituted acridinyl group.

[0100] X_1 to X_3 , R_7 , and c may be the same as respectively defined in connection with Formula 2-1 and Formula 2-2.

[0101] A polycyclic compound of an embodiment may be any one of the compounds shown in Compound Group 1:

Compound Group 1

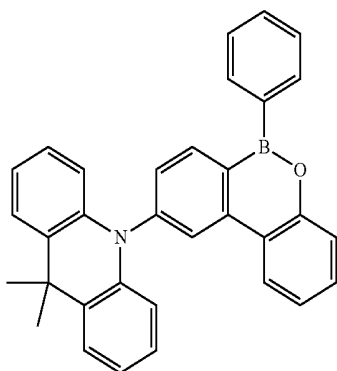

1

-continued

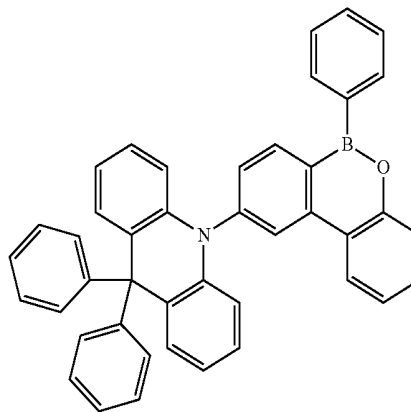

2

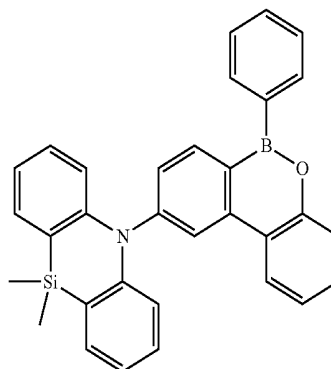

3

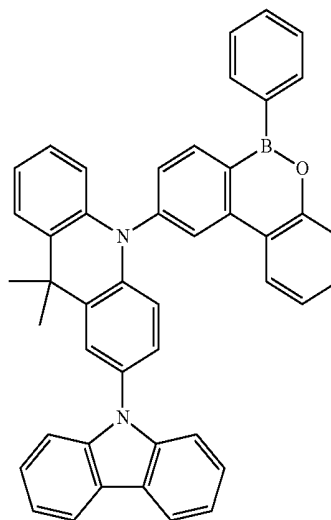

4

-continued

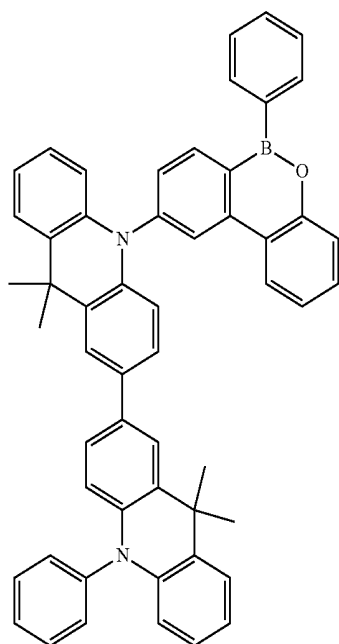

5

-continued

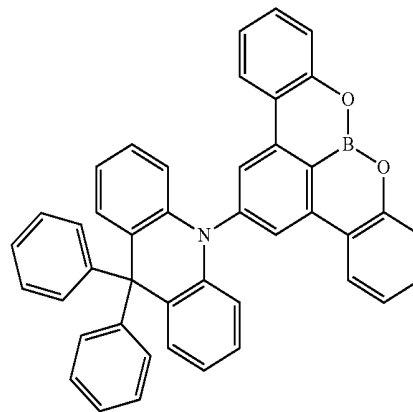

8

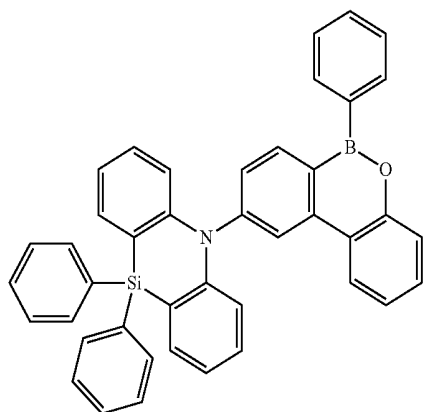

6

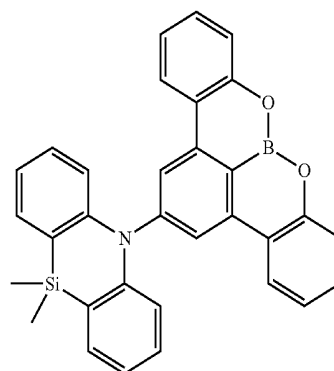

9

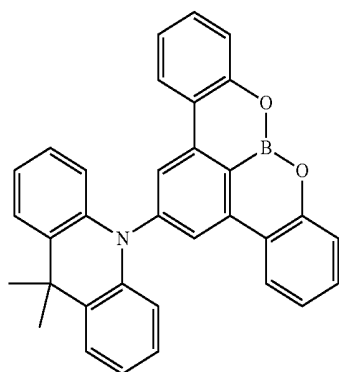

7

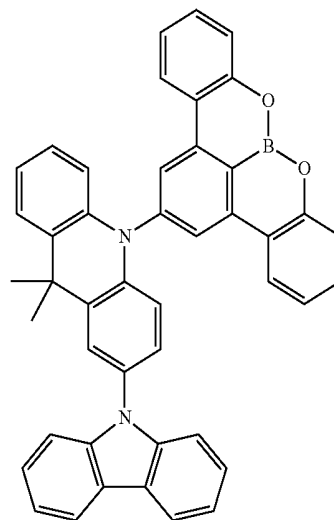

10

-continued

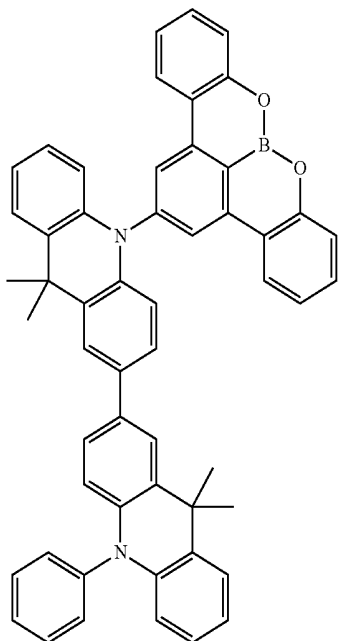

11

-continued

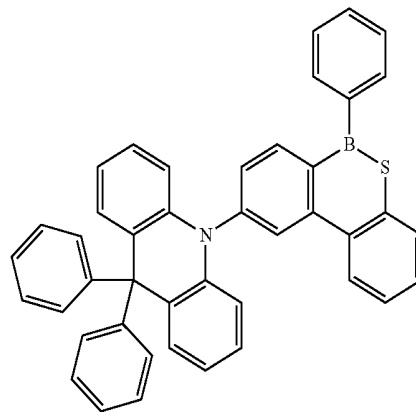

14

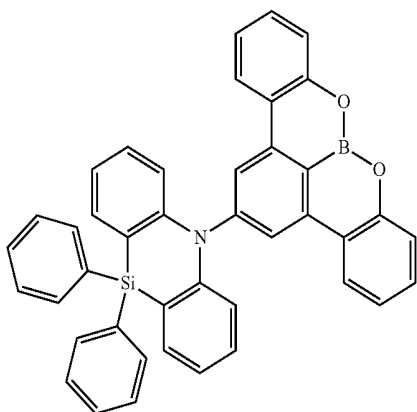

12

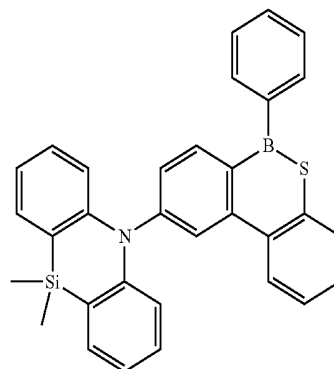

15

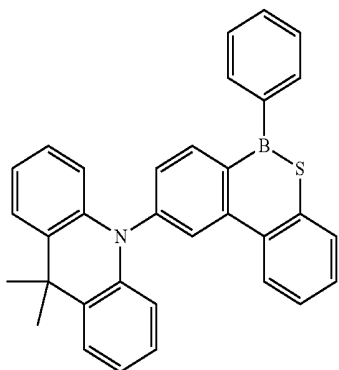

13

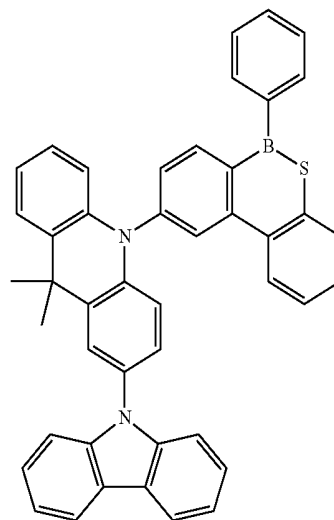

16

-continued

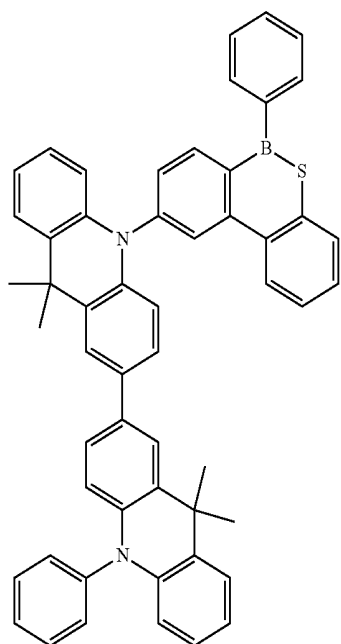

17

-continued

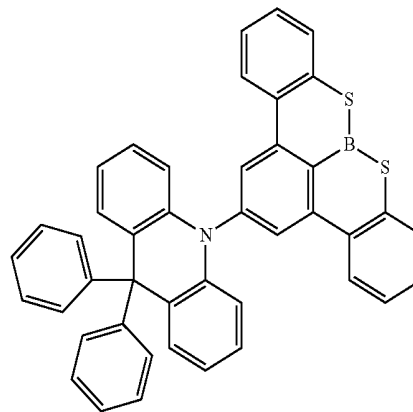

20

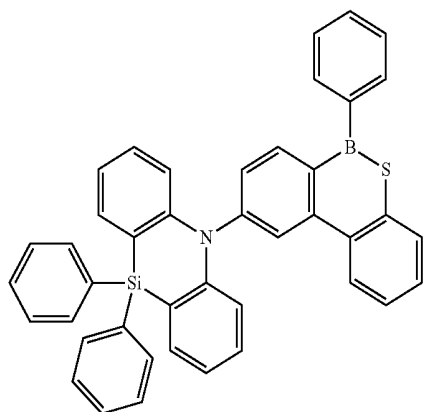

18

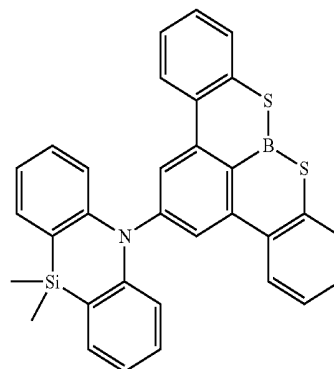

21

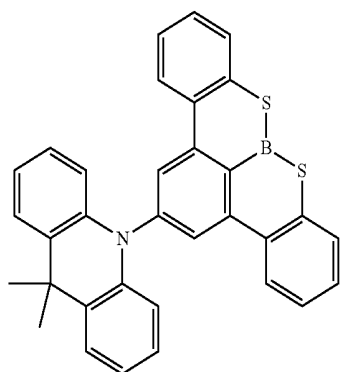

19

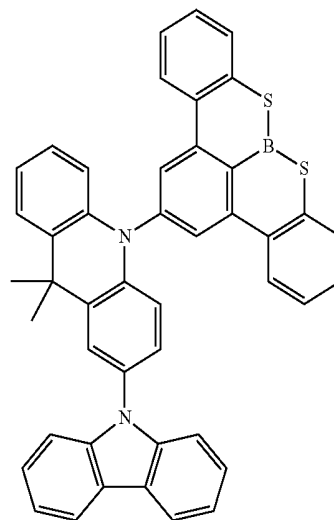

22

-continued

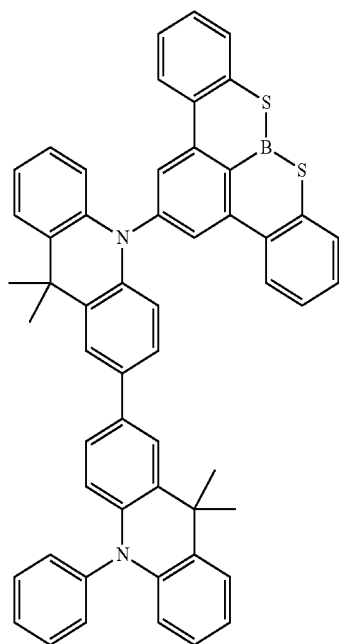

23

-continued

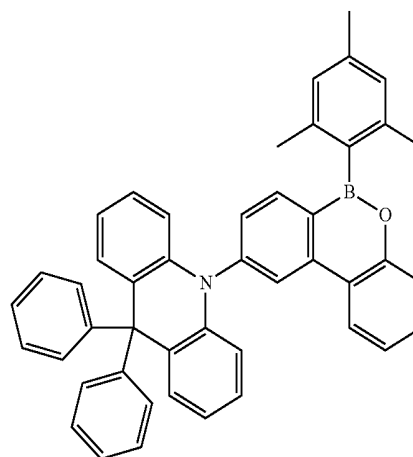

26

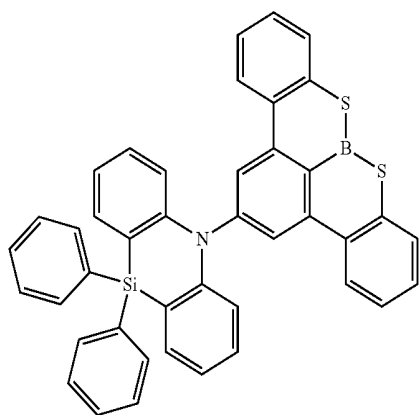

24

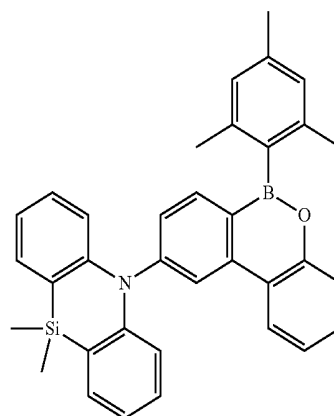

27

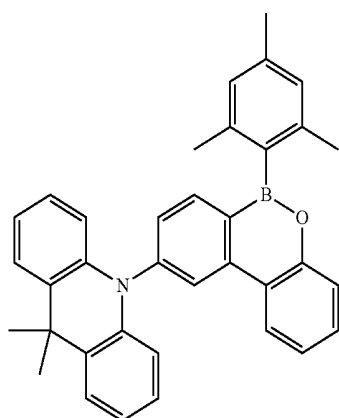

25

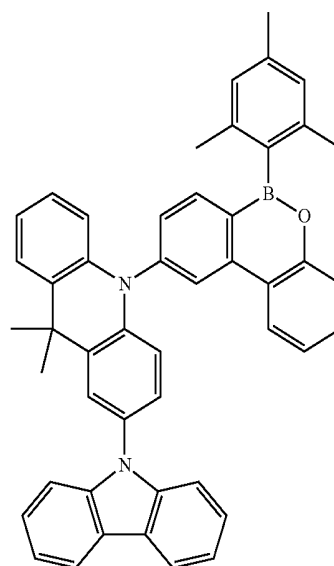

28

-continued

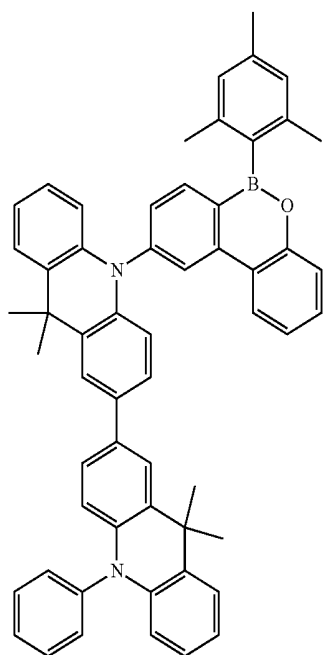

29

-continued

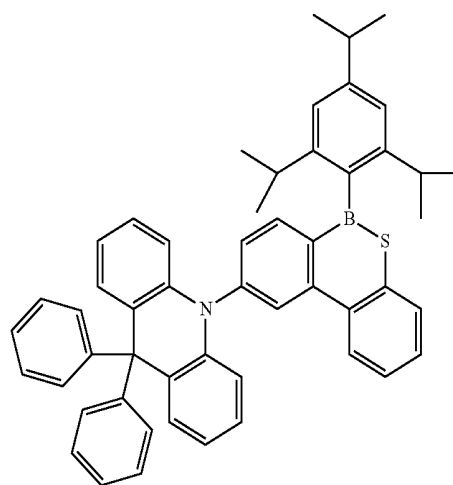

32

30

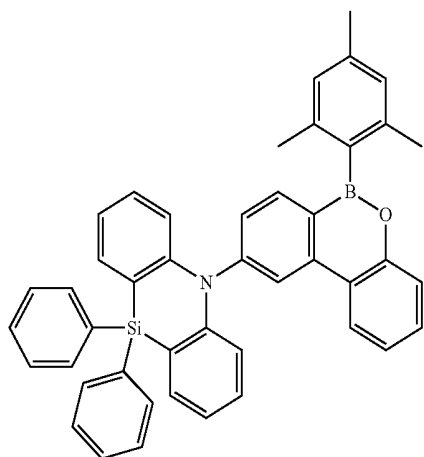

33

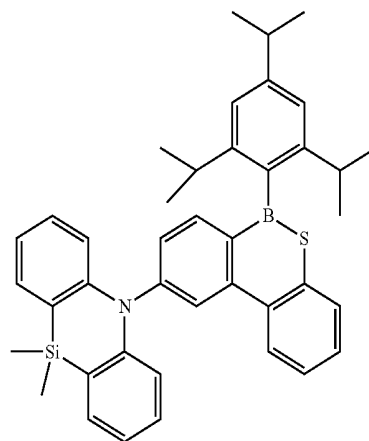

34

31

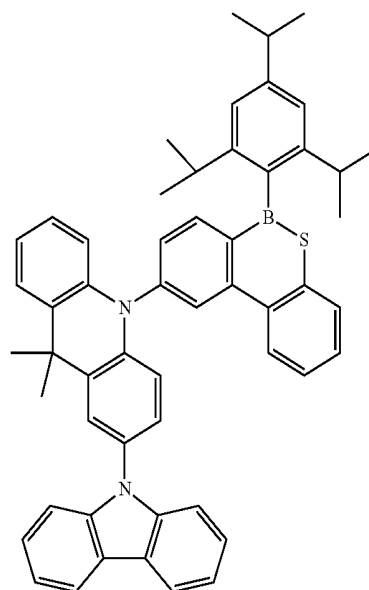
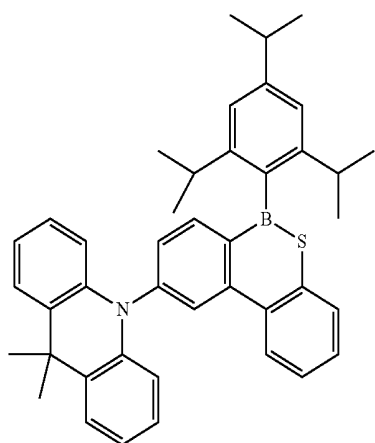

-continued

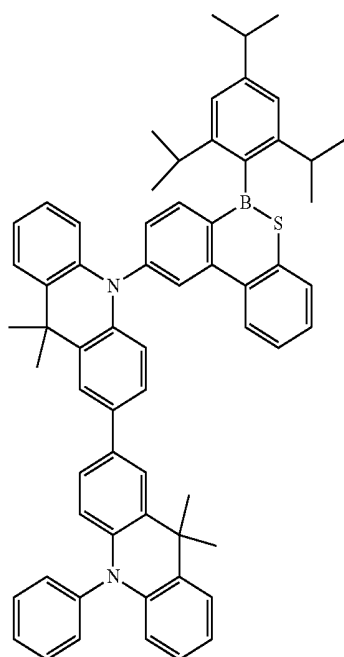

-continued

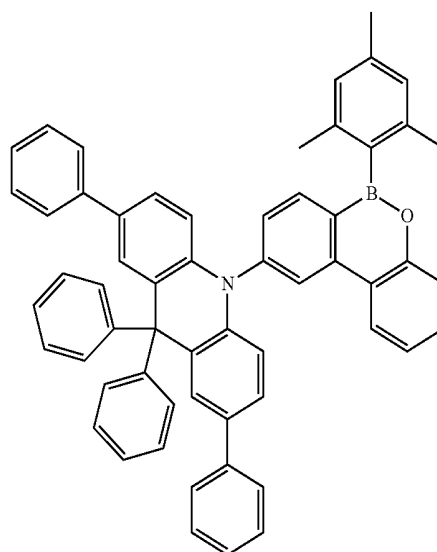

38

39

36

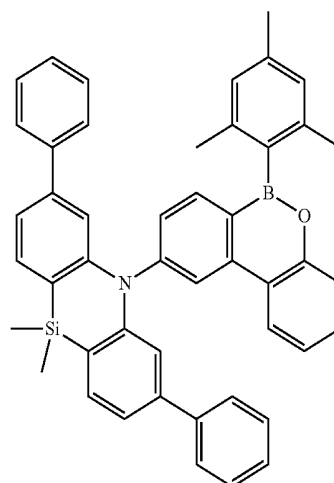
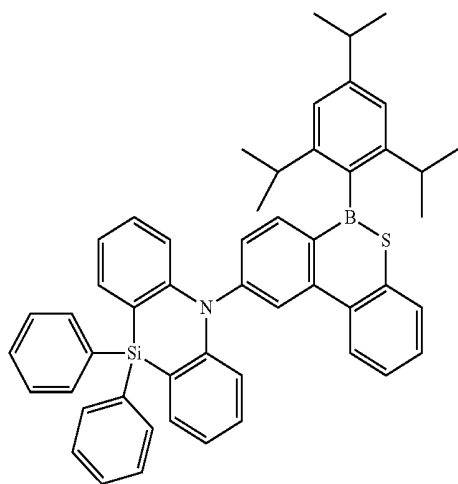

40

37

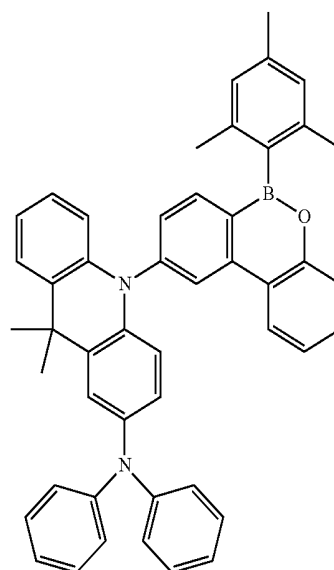
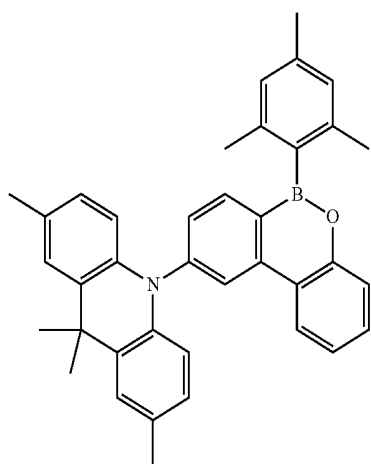

-continued

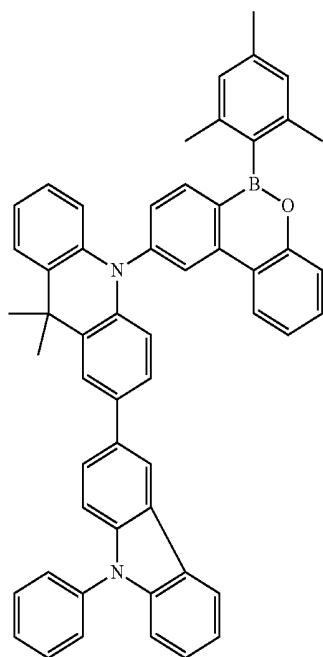

-continued

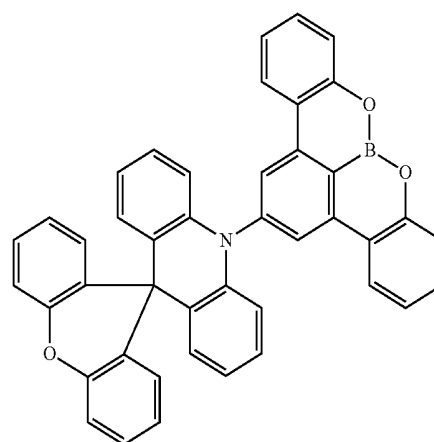

44

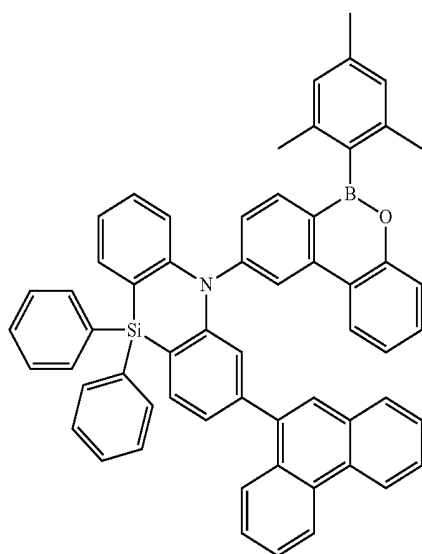

42

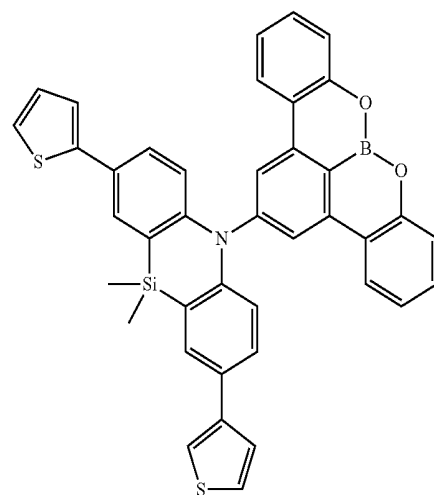

45

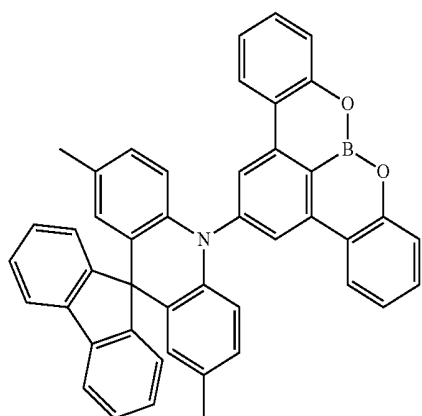

43

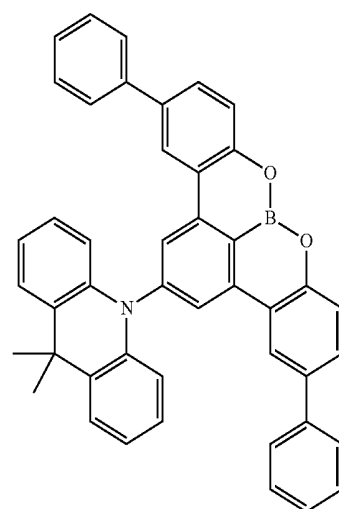

46

-continued

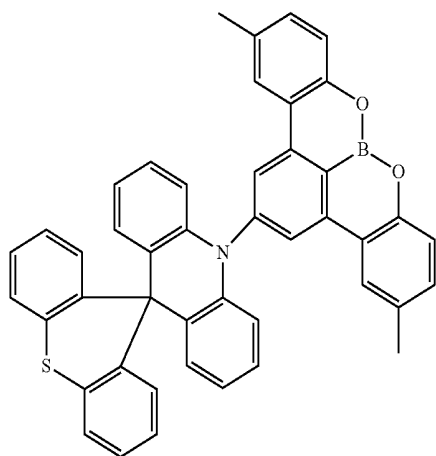

47

-continued

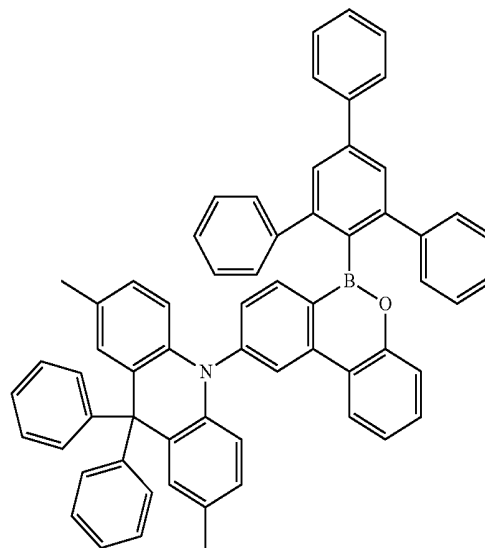

48

50

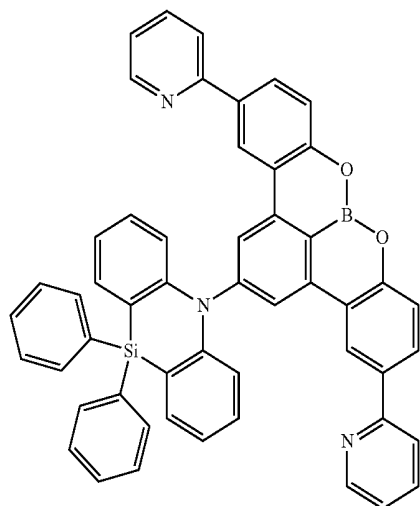

49

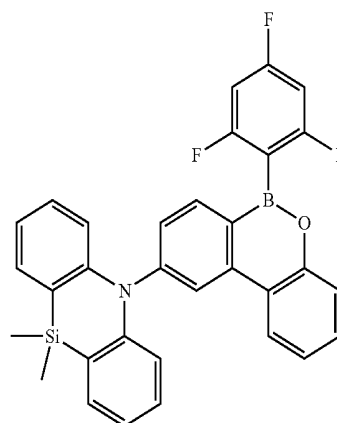

51

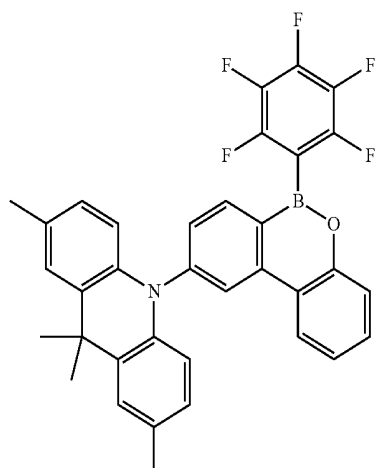

52

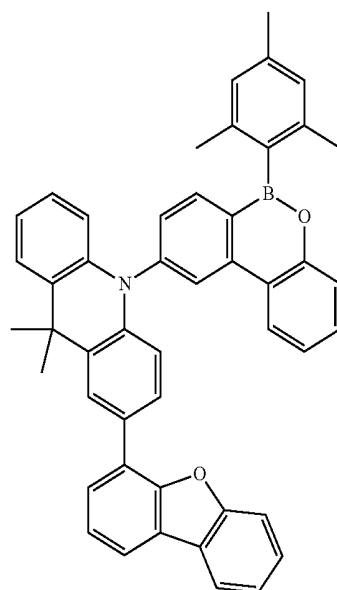

-continued

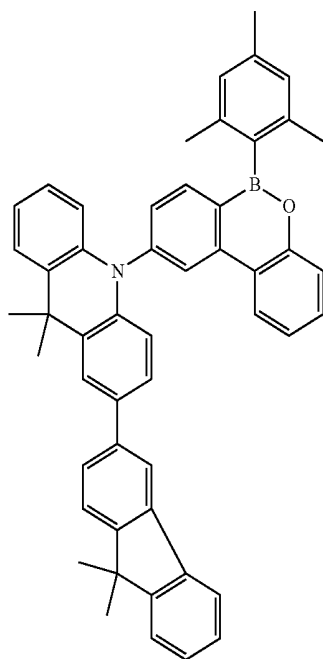

-continued

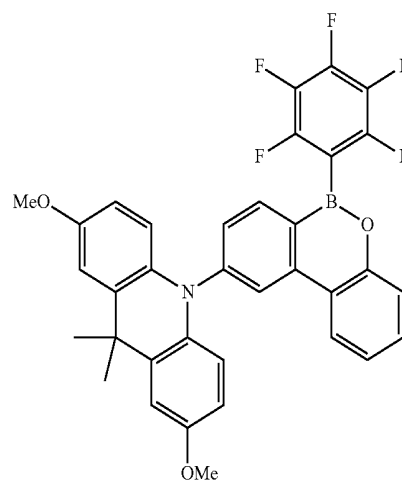

53

55

54

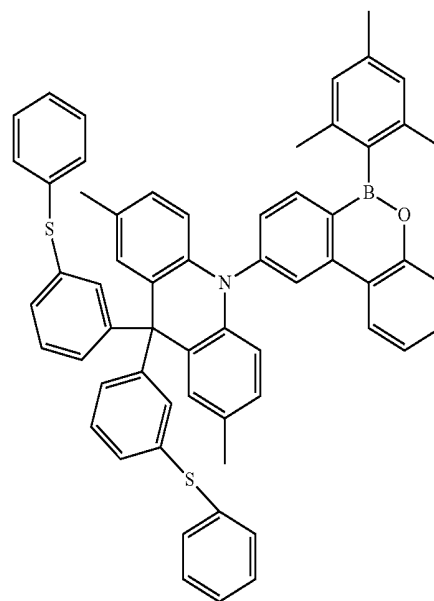
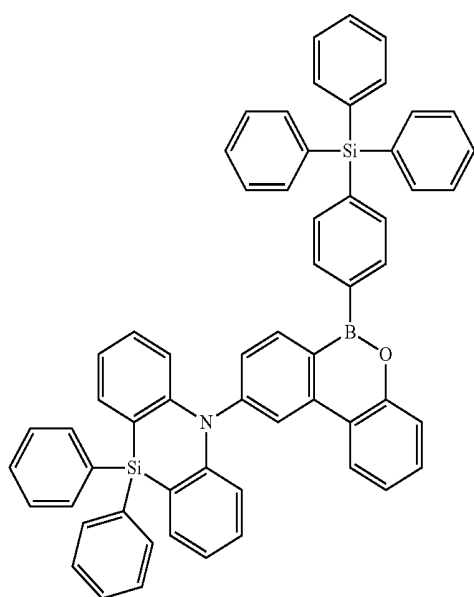

56

57

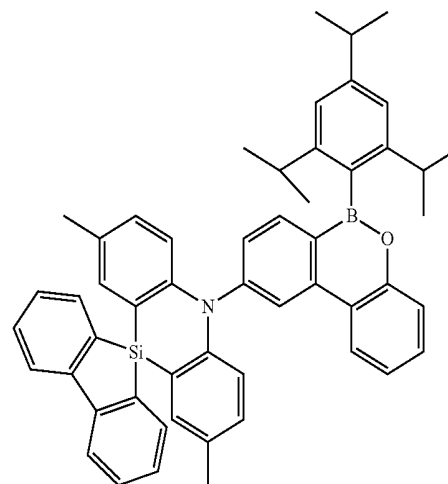

-continued

58

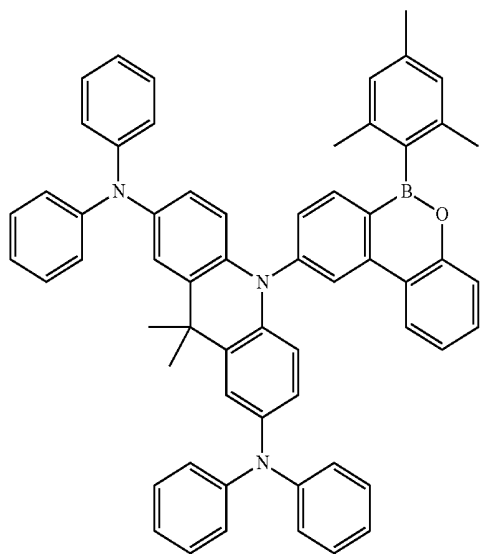

-continued

62

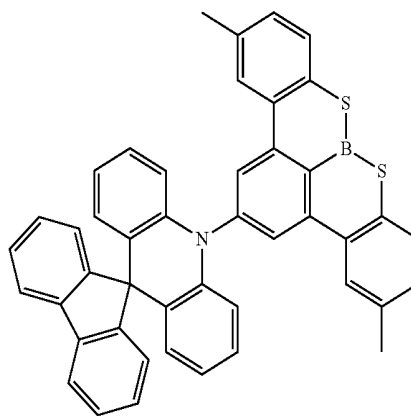

60

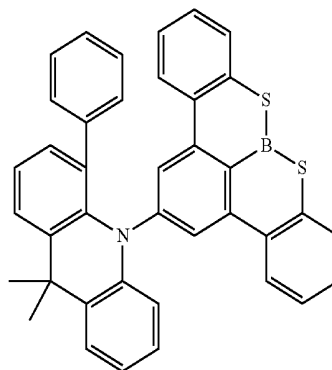

63

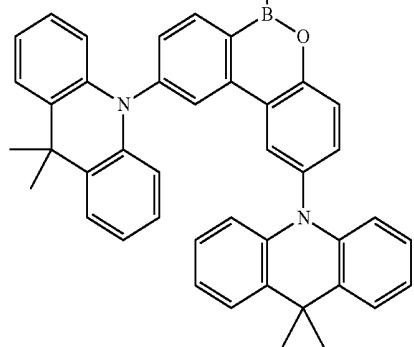
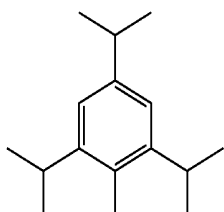

61

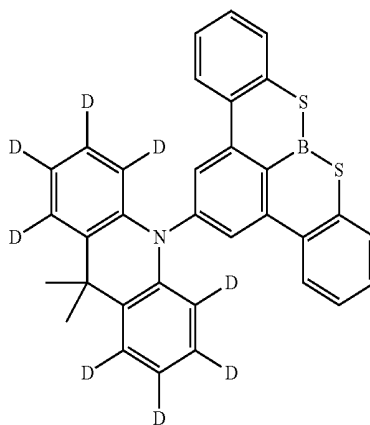

64

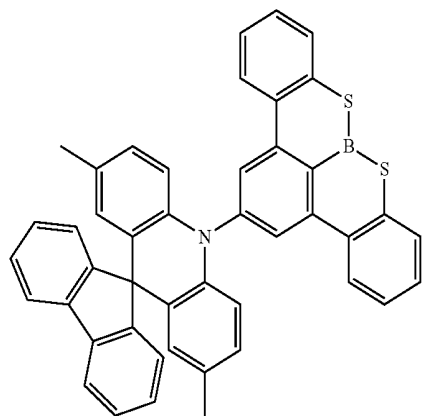

61

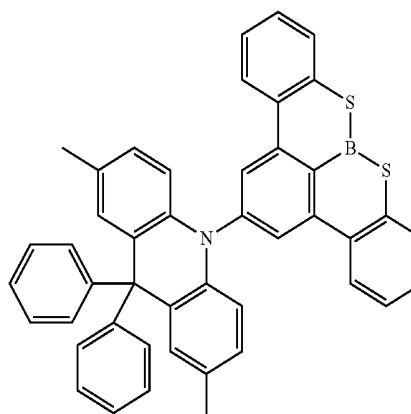

65

-continued

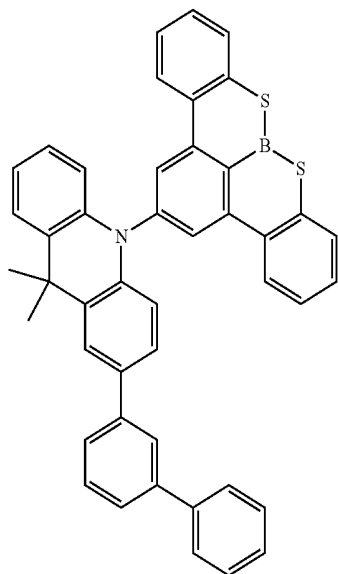

-continued

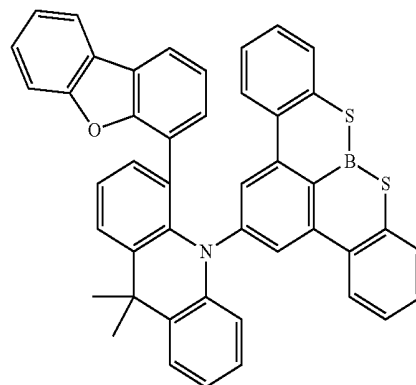

67

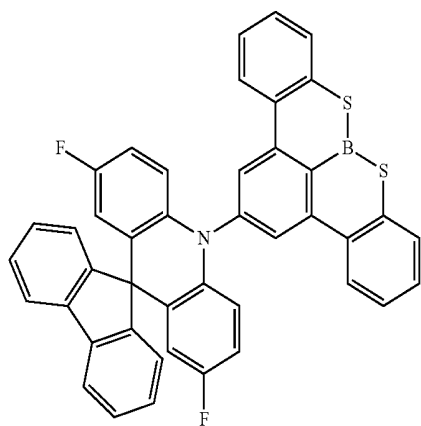

70

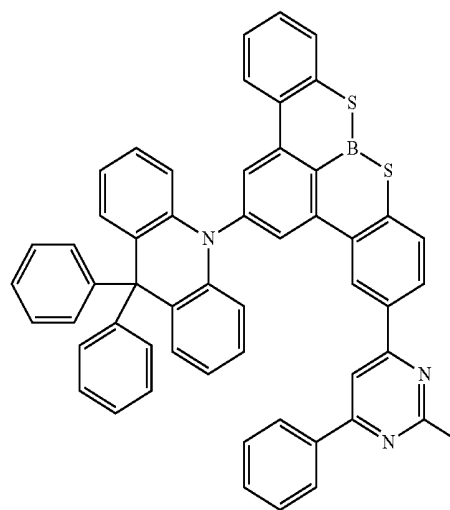

68

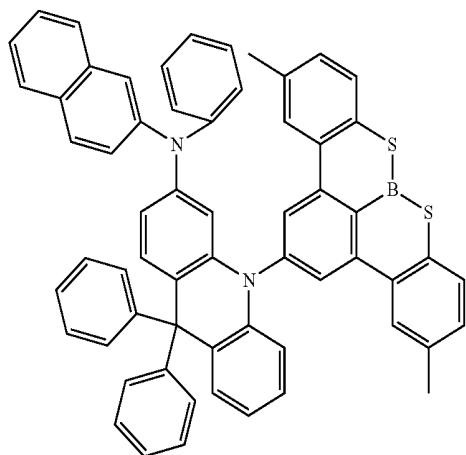

71

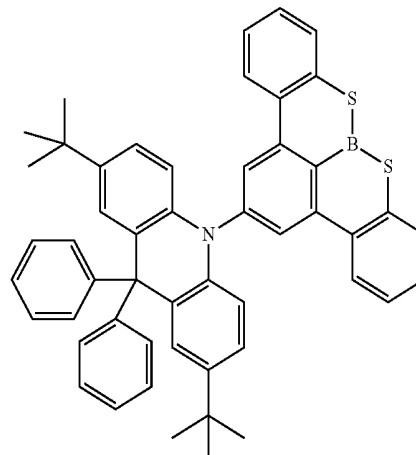

-continued

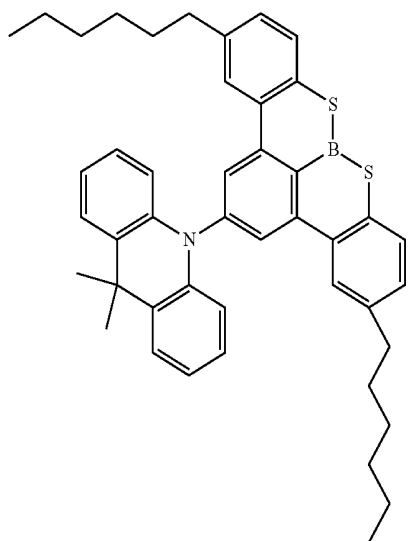

72

-continued

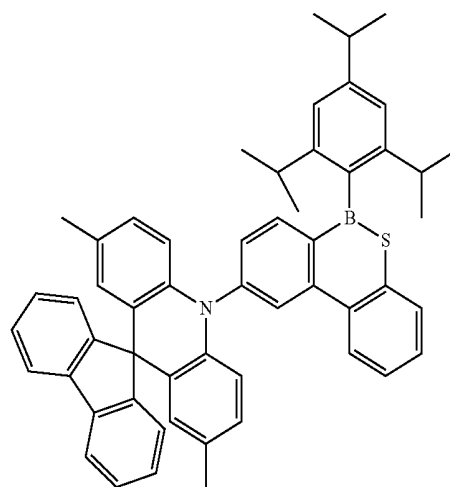

75

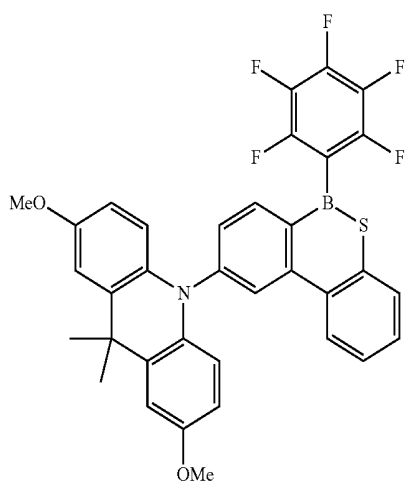

73

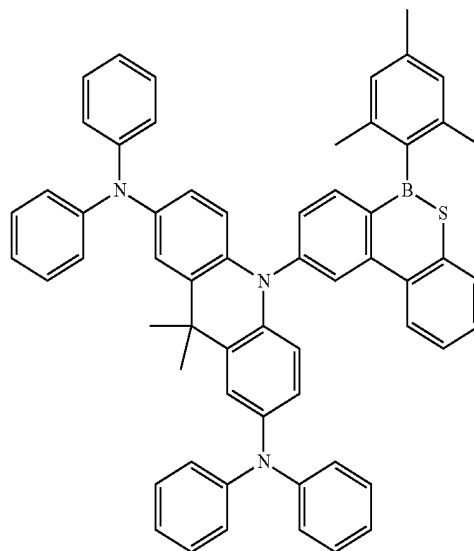

76

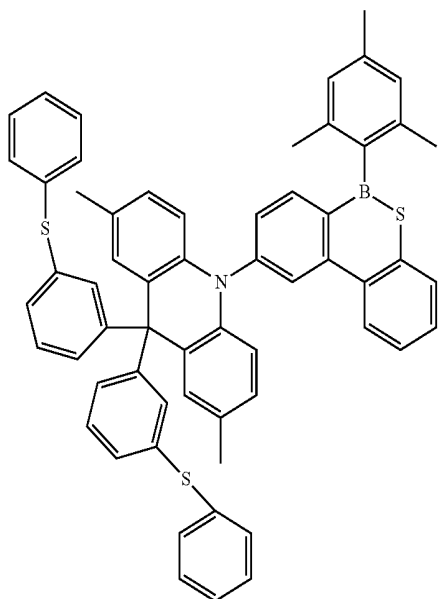

74

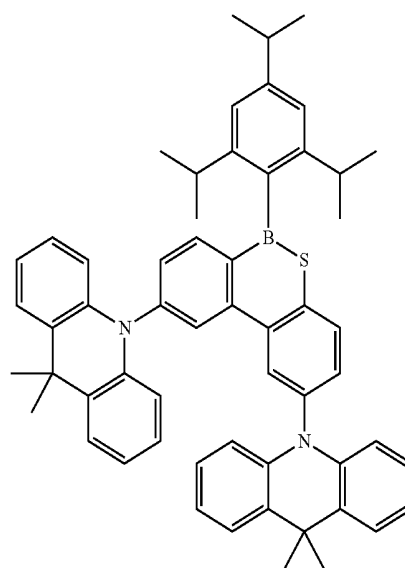

78

-continued

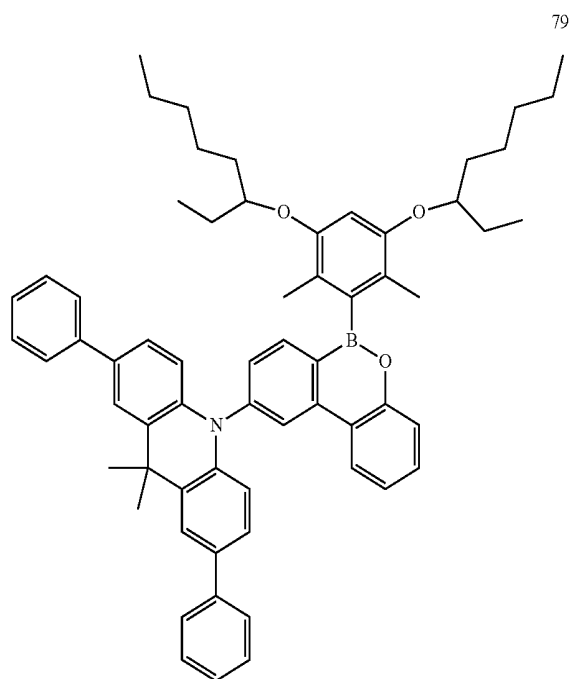

-continued

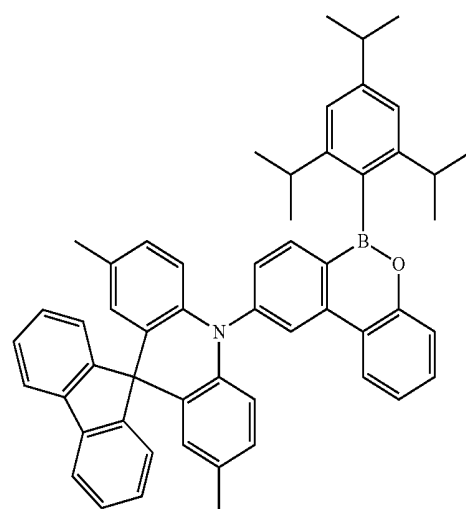

81

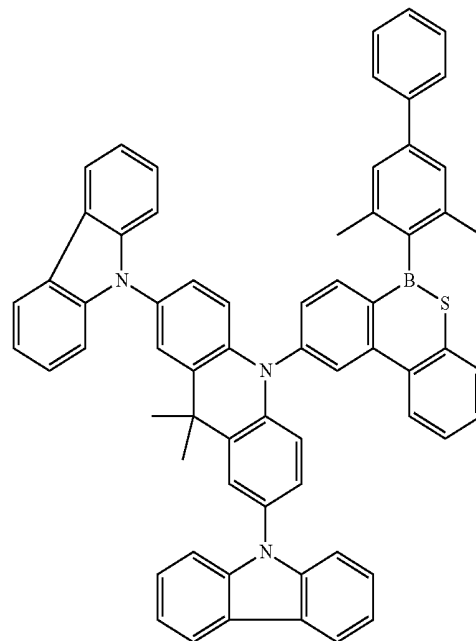

82

80

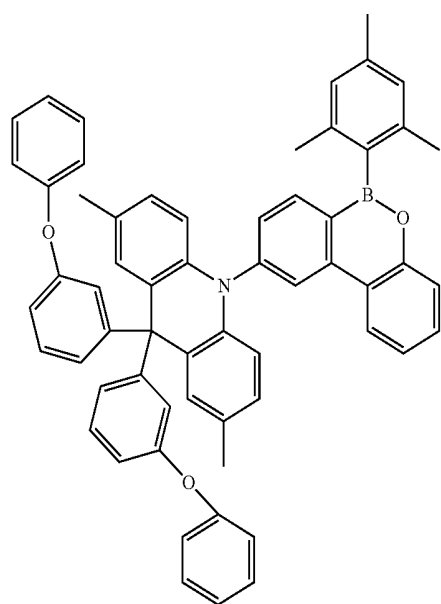

83

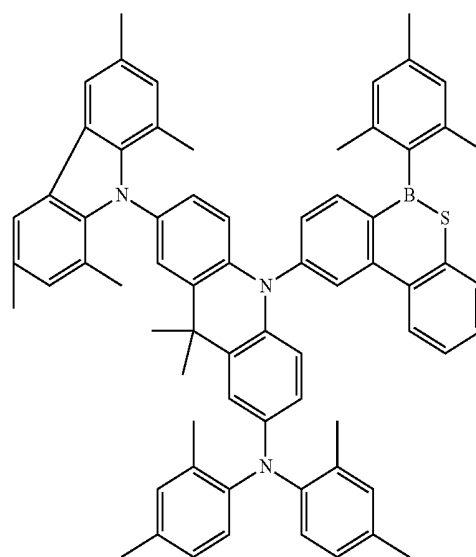

-continued

84

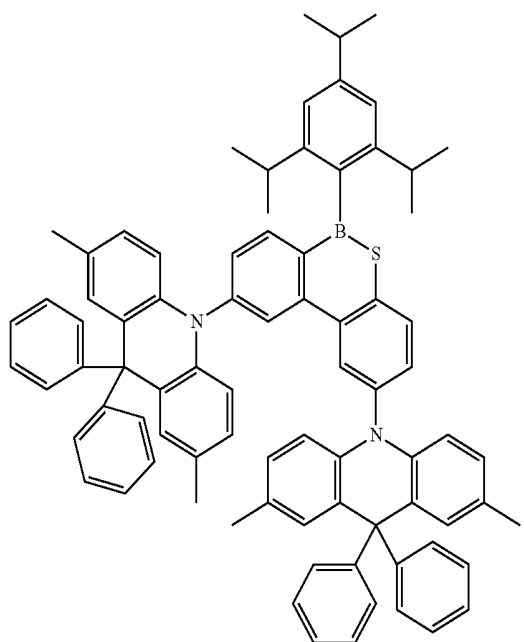

[0102] The emission layer EML may include one, two, or more polycyclic compounds of an embodiment.

[0103] The emission layer EML may further include a suitable (e.g., known) material in addition to a polycyclic compound of an embodiment. In the organic electroluminescence device 10 of an embodiment, the emission layer EML may include, for example, an anthracene derivative, a pyrene derivative, a fluoranthene derivative, a chrysene derivative, a dihydrobenzanthracene derivative, or a triphenylene derivative. For example, the emission layer EML may include an anthracene derivative or a pyrene derivative.

[0104] In the organic electroluminescence device 10 of an embodiment illustrated in FIGS. 1 to 3, the emission layer EML may include a host and a dopant, and the emission layer EML may include the described polycyclic compound as a dopant material. However, embodiments of the present disclosure are not limited thereto, and a polycyclic compound of an embodiment may be utilized (e.g., contained) as a host material in the emission layer EML.

[0105] A polycyclic compound of an embodiment may be included in the emission layer EML as a dopant for thermally activated delayed fluorescence.

[0106] The emission layer EML may emit light in a visible light range by including a polycyclic compound of an embodiment. For example, the emission layer EML may emit green light or blue light. For example, the emission layer EML may emit visible light having a wavelength range of about 440-540 nm or about 440-500 nm.

[0107] The emission layer EML may include a suitable material (e.g., a typical material known in the art) as a host material. The emission layer EML may include a host material, for example, bis[2-(diphenylphosphino)phenyl] ether oxide (DPEPO), 4,4'-bis(carbazol-9-yl)biphenyl (CBP), 1,3-bis(carbazol-9-yl)benzene (mCP), 2,8-bis(diphenylphosphoryl)dibenzo[b,d]furan (PPF), 4,4',4''-tris(carbazol-9-yl)-triphenylamine (TcTa), and/or 1,3,5-tris(N-phenylbenzimidazole-2-yl)benzene (TPBi). However,

embodiments of the present disclosure are not limited thereto, and for example, tris(8-hydroxyquinolino)aluminum (Alq₃), 4,4'-bis(N-carbazolyl)-1,1'-biphenyl (CBP), poly(n-vinylcarbazole) (PVK), 9,10-di(naphthalene-2-yl)anthracene (ADN), 4,4',4''-tris(carbazol-9-yl)-triphenylamine (TCTA), 1,3,5-tris(N-phenylbenzimidazole-2-yl)benzene (TPBi), 3-tert-butyl-9,10-di(naphth-2-yl)anthracene (TBADN), distyrylarylene (DSA), 4,4'-bis(9-carbazolyl)-2,2'-dimethyl-biphenyl (CDBP), 2-methyl-9,10-bis(naphthalen-2-yl)anthracene (MADN), bis[2-(diphenylphosphino)phenyl]ether oxide (DPE PO), hexaphenyl cyclotriphosphazene (CP1), 1,4-bis(triphenylsilyl)benzene (UGH2), hexaphenylcyclotrisiloxane (DPSiO₃), octaphenylcyclo-tetrasiloxane (DPSiO₄), 2,8-bis(diphenylphosphoryl)dibenzofuran (PPF), and/or the like may be utilized as a host material.

[0108] In an embodiment, the emission layer EML may include a suitable (e.g., known) dopant material, for example, styryl derivatives (for example, 1,4-bis[2-(3-N-ethylcarbazoryl)vinyl]benzene (BCzVB), 4-(di-p-tolylamino)-4'-[(di-p-tolylamino)styryl]stilbene (DPAVB), and/or N-(4-(E)-2-(6-(E)-4-(diphenylamino)styryl)naphthalen-2-Avinyl)phenyl)-N-phenylbenzenamine (N-BDAVB)), perylene and derivatives thereof (for example, 2,5,8,11-tetra-*t*-butylperylene (TBP)), pyrene and derivatives thereof (for example, 1,1-dipyrene, 1,4-dipyrenylbenzene, and/or 1,4-bis(N,N-diphenylamino)pyrene), and/or the like.

[0109] In the organic electroluminescence device 10 of an embodiment illustrated in FIGS. 1 to 3, the electron transport region ETR may be disposed on the emission layer EML. The electron transport region ETR may include a hole blocking layer HBL, an electron transport layer ETL, and/or an electron injection layer EIL, but embodiments of the present disclosure are not limited thereto.

[0110] The electron transport region ETR may have a structure of: a single layer formed of a single material; a single layer formed of a plurality of different materials; or a multi-layer having a plurality of layers formed of a plurality of different materials.

[0111] For example, the electron transport region ETR may have a structure of a single layer which is an electron injection layer EIL or an electron transport layer ETL, or may have a structure of a single layer formed of an electron injection material and an electron transport material. In some embodiments, the electron transport region ETR may have a structure of a single layer formed of a plurality of different materials, or may have a structure of, sequentially laminated from the emission layer EML, electron transport layer ETL/electron injection layer EIL or hole blocking layer HBL/electron transport layer ETL/electron injection layer EIL, but embodiments of the present disclosure are not limited thereto. A thickness of the electron transport region ETR may be, for example, from about 1000-1500 Å.

[0112] The electron transport region ETR may be formed utilizing various suitable methods such as a vacuum deposition method, a spin coating method, a casting method, a Langmuir-Blodgett (LB) method, an inkjet printing method, a laser printing method, and/or a laser induced thermal imaging (LITI) method.

[0113] When the electron transport region ETR includes the electron transport layer ETL, the electron transport region ETR may include an anthracene-based compound. However, embodiments of the present disclosure are not limited thereto, and the electron transport region ETR may

include, for example, tris(8-hydroxyquinolino)aluminum (Alq_3), 1,3,5-tri[(3-pyridyl)-phen-3-yl]benzene, 2,4,6-tris(3'-(pyridin-3-yl)biphenyl-3-yl)-1,3,5-triazine, 2-(4-(N-phenylbenzimidazolyl-1-yl)phenyl)-9,10-dinaphthylanthracene, 1,3,5-tri(1-phenyl-1H-benzo[d]imidazol-2-yl)benzene (TPBi), 2,9-dimethyl-4,7-diphenyl-1,10-phenanthroline (BCP), 4,7-diphenyl-1,10-phenanthroline (Bphen), 3-(4-biphenyl)-4-phenyl-5-tert-butylphenyl-1,2,4-triazole (TAZ), 4-(naphthalen-1-yl)-3,5-diphenyl-4H-1,2,4-triazole (NTAZ), 2-(4-biphenyl)-5-(4-tert-butylphenyl)-1,3,4-oxadiazole (tBu-PBD), bis(2-methyl-8-quinolinolato-N1,O8)-(1,1'-biphenyl-4-olato)aluminum (BAIq), berylliumbis(benzoquinolin-10-olate) (Beq_2), 9,10-di(naphthalene-2-yl)anthracene (ADN), or a mixture thereof. A thickness of the electron transport layer ETL may be about 100-1000 Å, for example, about 150-500 Å. When the thickness of the electron transport layer ETL satisfies the above described ranges, suitable or satisfactory electron transport performance may be achieved without substantial rise of a driving voltage.

[0114] When the electron transport region ETR includes the electron injection layer EIL, the electron transport region ETR may include (e.g., employ): an alkaline metal or an alkaline earth metal containing compound (such as LiF, lithium quinolate (LiQ), Li_2O , BaO, NaCl, CsF), a lanthanide metal (such as Yb), or a halogenated metal (such as RbCl and/or RbI), but embodiments of the present disclosure are not limited thereto. The electron injection layer EIL may also be formed of a mixture of an electron transport material and an insulating organo-metal salt. The organo-metal salt may be a material having an energy band gap of about 4 eV or more. For example, the organo-metal salt may contain, for example, a metal acetate, a metal benzoate, a metal acetoacetate, a metal acetylacetonate, and/or a metal stearate. Thickness of the electron injection layer EIL may be about 1-100 Å, for example, about 3-90 Å. When the thickness of the electron injection layer EIL satisfies the above described ranges, suitable or satisfactory electron injection performance may be achieved without substantial rise of a driving voltage.

[0115] The electron transport region ETR may include a hole blocking layer HBL as described above. The hole blocking layer HBL may include, for example, 2,9-dimethyl-4,7-diphenyl-1,10-phenanthroline (BCP) and/or 4,7-diphenyl-1,10-phenanthroline (Bphen), but embodiments of the present disclosure are not limited thereto. A thickness of the hole blocking layer HBL may be about 100-1000 Å, for example, about 150-500 Å. When the thickness of the hole blocking layer HBL satisfies the above described ranges, suitable or satisfactory hole blocking performance may be achieved without substantial rise of a driving voltage.

[0116] The second electrode EL2 may be disposed on the electron transport region ETR. The second electrode EL2 may be a common electrode or a negative electrode. The second electrode EL2 may be a transmissive electrode, a transfective electrode, or a reflective electrode. When the second electrode EL2 is a transmissive electrode, the second electrode EL2 may be formed of a transparent metal oxide, for example, indium tin oxide (ITO), indium zinc oxide (IZO), zinc oxide (ZnO), indium tin zinc oxide (ITZO), and/or the like.

[0117] When the second electrode EL2 is a transfective electrode or a reflective electrode, the second electrode EL2 may include Ag, Mg, Cu, Al, Pt, Pd, Au, Ni, Nd, Ir, Cr, Li,

Ca, LiF/Ca, LiF/Al, Mo, Ti, or a compound or a mixture thereof (for example, a mixture of Ag and Mg). In some embodiments, the second electrode EL2 may have a structure which has a plurality of layers including: a reflective layer or a transfective layer formed of the above described materials; and a transparent conductive layer formed of ITO, IZO, ZnO, ITZO, and/or the like.

[0118] In one embodiment, the second electrode EL2 may be connected to an auxiliary electrode. When the second electrode EL2 is connected to the auxiliary electrode, the resistance of the second electrode EL2 may be reduced.

[0119] In one embodiment, a capping layer may be further disposed on the second electrode EL2 of the organic electroluminescence device 10 of an embodiment. The capping layer may include, for example, α -NPD, NPB, TPD, m-MTDATA, Alq_3 , Cu Pc, N4,N4,N4',N4'-tetra(biphenyl-4-yl)biphenyl-4,4'-diamine (TPD15), 4,4',4''-tris(carbazol-9-yl)-triphenylamine (TCTA), N,N'-bis(naphthalene-1-yl), and/or the like.

[0120] The polycyclic compound of an embodiment described above may be included as a material for the organic electroluminescence device 10 in the organic layer in addition to the emission layer EML. The organic electroluminescence device 10 according to an embodiment of the present disclosure may include the polycyclic compound in at least one organic layer disposed between the first electrode EL1 and the second electrode EL2, or in a capping layer disposed on the second electrode EL2.

[0121] In the organic electroluminescence device 10, as a voltage is applied to the first electrode EL1 and the second electrode EL2 respectively, the holes injected from the first electrode EL1 may move through the hole transport region HTR to the emission layer EML, and the electrons injected from the second electrode EL2 may move through the electron transport region ETR to the emission layer EML. The electrons and the holes may be recombined in the emission layer EML to generate excitons, and the excitons may emit light when the excitons fall back from an excited state to a ground state.

[0122] According to an embodiment of the present disclosure, an organic electroluminescence device 10 having high efficiency may be achieved.

[0123] According to an embodiment of the present disclosure, a polycyclic compound may be applied to (e.g., included in) an organic electroluminescence device 10 to improve efficiency.

[0124] According to an embodiment of the present disclosure, a polycyclic compound may have a difference between a lowest singlet energy level and a lowest triplet energy level of 0.2 eV or less, 0.15 eV or less, or 0.1 eV or less, and thus the polycyclic compound may be utilized as a thermally activated delayed fluorescent material. Therefore, according to an embodiment of the present disclosure, the polycyclic compound may be applied as a material for an organic electroluminescence device, thereby contributing to improved efficiency.

[0125] Hereinafter, a polycyclic compound according to an embodiment of the present disclosure and an organic electroluminescence device 10 of an embodiment including the polycyclic compound of an embodiment will be explained in more detail with reference to examples and comparative examples. In addition, the following embodiments are only examples to assist the understanding of the

subject matter of the present disclosure, and the scope of the present disclosure is not limited thereto.

[0126] (Synthesis Example)

[0127] A polycyclic compound according to an embodiment of the present disclosure may be synthesized, for example, as in the following examples. However, the synthesis method of the polycyclic compound according to an embodiment of the present disclosure is not limited thereto.

[0128] 1-1. Synthesis of Compounds 43 and 61

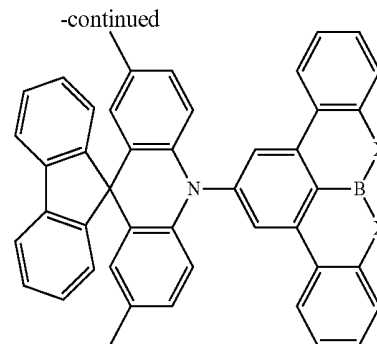
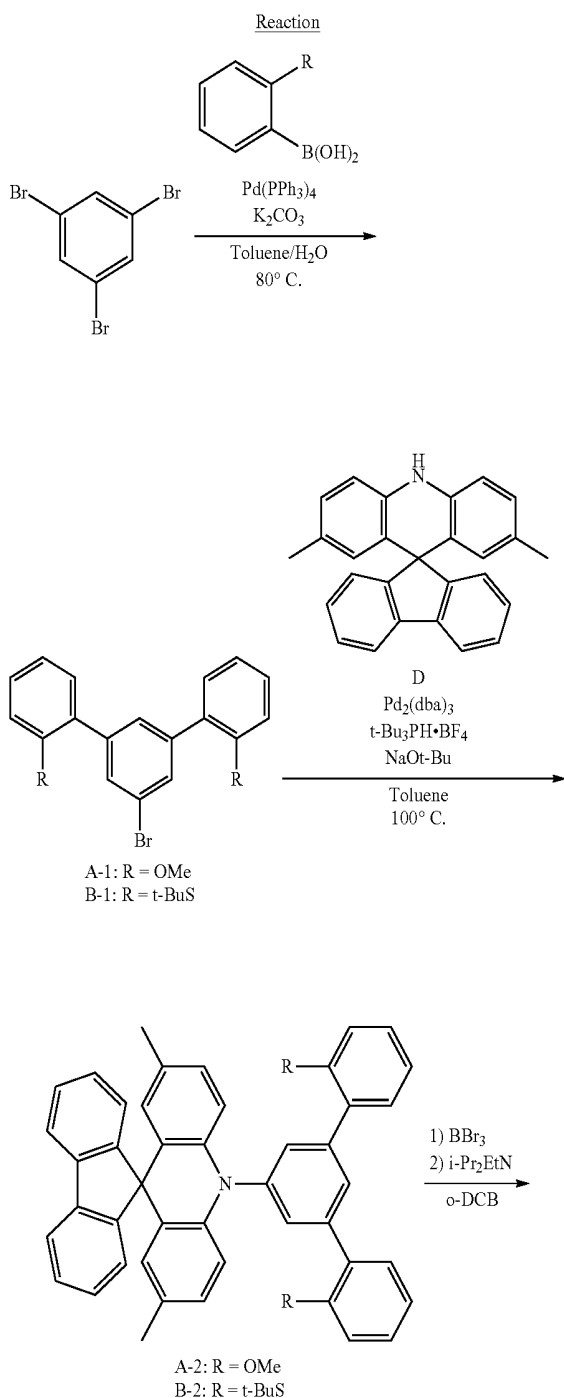

43: X = O
61: X = S

[0129] Synthesis of intermediate A-1

[0130] A mixture of 2-methoxyphenylboronic acid (1.83 g, 12.0 mmol), 1,3,5-tribromobenzene (1.89 g, 6.00 mmol), Pd(PPh₃)₄ (136 mg, 0.118 mmol), and K₂CO₃ (3.32 g, 24.0 mmol) was added to a mixed solvent of toluene (60 ml) and water (20 ml) under nitrogen atmosphere, and the mixture was stirred at 80° C. for 24 hours. Then, water was added thereto, and the product was extracted with toluene. The extracted organic layer was washed with brine, dried over anhydrous Na₂SO₄, and concentrated under reduced pressure. The resulting crude product was purified by silica gel column chromatography (utilizing hexane and toluene at a volume ratio of 5:1 as an eluent) to obtain intermediate A-1 as a colorless viscous oil (yield of 54%: 1.19 g, 3.22 mmol).

[0131] The result for intermediate A-1 measured by ¹H NMR (400 MHz, CDCl₃) was as follows:

[0132] δ7.64 (d, J=1.6 Hz, 2H), δ7.60 (t, J=1.6 Hz, 1 H), δ7.36-7.31 (m, 4H), δ7.03 (ddd, J=7.2, 7.2, 1.2 Hz, 2H), δ6.90 (dd, J=8.0, 1.2 Hz, 2H), and δ3.83 (s, 6H).

[0133] Synthesis of intermediate A-2

[0134] A mixture of intermediate A-1 (554 mg, 1.50 mmol), D (542 mg, 1.50 mmol), Pd₂(dba)₃ (29 mg, 0.032 mmol), P(t-Bu)₃H·BF₄ (36 mg, 0.12 mmol), and sodium tert-butoxide (289 mg, 3.01 mmol) was added to toluene (7.5 ml) under nitrogen atmosphere, and the mixture was stirred at 100° C. for 20 hours. Then, a NH₄Cl aqueous solution was added thereto, and the product was extracted with toluene. The extracted organic layer was washed with brine, dried over anhydrous Na₂SO₄, and concentrated under reduced pressure. The resulting crude product was purified by silica gel column chromatography (utilizing hexane and toluene at a volume ratio of 1:1 as an eluent) to obtain intermediate A-2 as a white solid (yield of 83%: 809 mg, 1.25 mmol). The result for intermediate A-2 measured by ¹H NMR (400 MHz, CDCl₃) was as follows:

[0135] δ7.87 (t, J=1.6 Hz, 1H), δ7.80 (d, J=7.6 Hz, 2H), δ7.64 (d, J=1.6 Hz, 2H), δ7.49 (dd, J=7.6, 1.6 Hz, 2H), δ7.46 (d, J=7.6 Hz, 2H), δ7.39-7.33 (m, 4H), δ7.24 (ddd, J=7.6, 7.6, 1.6 Hz, 2H), δ7.07 (ddd, J=7.6, 7.6, 1.2 Hz, 2H), δ7.02 (d, J=8.0 Hz, 2H), δ6.77 (ddd, J=8.0, 1.6 Hz, 2H), δ6.60 (d, J=8.0 Hz, 2H), δ6.18 (d, J=2.0 Hz, 2H), δ3.86 (s, 6H), and δ1.96 (s, 6H).

[0136] Synthesis of Compound 43

[0137] Intermediate A-2 (648 mg, 1.00 mmol) was added to o-dichlorobenzene (o-DCB; 5 mL), and the mixture was stirred. Then, BBr₃ (1.0 M, 1.0 mL, 1.0 mmol, in heptane) was added thereto under nitrogen atmosphere at 0° C. The reaction solution was stirred at room temperature for 15

hours, and *N,N*-diisopropylethylamine (*i*-Pr₂EtN; 0.34 mL, 2.0 mmol) was added thereto. After removal of the solvent in vacuum, the resulting crude product was washed with hexane and acetonitrile to obtain compound 43 as a white solid (yield of 57%: 360 mg, 0.574 mmol). The result for compound 43 measured by ¹H NMR (400 MHz, CDCl₃) was as follows:

[0138] δ8.19 (s, 2H), δ8.16 (d, *J*=7.6 Hz, 2H), δ7.85 (d, *J*=7.2 Hz, 2H), δ7.54-7.49 (m, 6H), δ7.43 (ddd, *J*=7.6, 7.6, 1.2 Hz, 2H), δ7.35-7.29 (m, 4H), δ6.70 (dd, *J*=8.0, 2.0 Hz, 2H), δ6.31 (d, *J*=8.8 Hz, 2H), δ6.23 (d, *J*=2.4 Hz, 2H), and δ1.96 (s, 6H).

[0139] A [M]⁺ value of compound 43 measured by matrix assisted laser desorption/ionization-time of flight mass spectrometry (MALDI-TOF MS) measurement was 627.45 (m/z).

[0140] Synthesis of intermediate B-1

[0141] A mixture of (2-(*tert*-butylthio)phenyl)boronic acid (2.56 g, 12.2 mmol), 1,3,5-tribromobenzene (1.91 g, 6.07 mmol), Pd(PPh₃)₄ (209 mg, 0.181 mmol), and K₂CO₃ (3.36 g, 24.3 mmol) was added to a mixed solvent of toluene (45 ml) and water (15 ml) under nitrogen atmosphere, and the mixture was stirred at 80° C. for 24 hours. Then, water was added thereto, and the product was extracted with ethyl acetate. The extracted organic layer was washed with brine, dried over anhydrous Na₂SO₄, and concentrated under reduced pressure. The resulting crude product was purified by silica gel column chromatography (utilizing hexane and toluene at a volume ratio of 10:1 as an eluent) to obtain intermediate B-1 as a colorless viscous oil (yield of 77%: 2.26 g, 4.65 mmol). The result for intermediate B-1 measured by ¹H NMR (400 MHz, CDCl₃) was as follows:

[0142] δ7.70 (d, *J*=8.0 Hz, 2H), δ7.55 (d, *J*=1.6 Hz, 2H), δ7.41-7.38 (m, 5H), δ7.35-7.30 (m, 2H), δ6.90 (dd, *J*=8.0, 1.2 Hz, 2H), and δ1.10 (s, 18H).

[0143] Synthesis of intermediate B-2

[0144] A mixture of intermediate B-1 (1.43 g, 2.95 mmol), D (1.12 g, 3.10 mmol), Pd₂(dba)₃ (55 mg, 0.060 mmol), P(*t*-Bu)₃H·BF₄ (69 mg, 0.24 mmol), and sodium *tert*-butoxide (575 mg, 5.98 mmol) was added to toluene (15 ml) under nitrogen atmosphere, and the mixture was stirred at 100° C. for 20 hours. Then, a NH₄Cl aqueous solution was added thereto and the product was extracted with toluene. The extracted organic layer was washed with brine, dried over anhydrous Na₂SO₄, and concentrated under reduced pressure. The resulting crude product was purified by silica gel column chromatography (utilizing hexane and toluene at a volume ratio of 2:1 as an eluent) to obtain intermediate B-2 as a white solid (yield of 87%: 1960 mg, 2.57 mmol). The result for intermediate B-2 measured by ¹H NMR (400 MHz, CDCl₃) was as follows:

[0145] δ7.80 (d, *J*=7.6 Hz, 2H), δ7.74 (dd, *J*=7.6, 1.2 Hz, 2H), δ7.65 (t, *J*=1.6 Hz, 1H), δ7.57 (dd, *J*=7.6, 1.6 Hz, 2H), δ7.54 (d, *J*=1.6 Hz, 2H), δ7.48-7.43 (m, 4H), δ7.38 (dd, *J*=7.6, 1.2 Hz, 2H), δ7.34 (dd, *J*=7.6, 1.2 Hz, 2H), δ7.25 (ddd, *J*=7.6, 7.6, 1.2 Hz, 2H), δ6.73 (dd, *J*=8.4, 1.6 Hz, 2H), δ6.60 (d, *J*=8.4 Hz, 2H), δ6.16 (d, *J*=2.0 Hz, 2H), δ1.95 (s, 6H), and δ1.17 (s, 18H).

[0146] Synthesis of Compound 61

[0147] Intermediate B-2 (1.15 g, 1.50 mmol) was added to *o*-dichlorobenzene (9 mL), and the mixture was stirred. Then, BBr₃ (1.0 M, 1.5 mL, 1.5 mmol, in heptane) was added thereto under nitrogen atmosphere at 0° C. The reaction mixture was stirred at 40° C. for 15 hours, and

N,N-diisopropylethylamine (0.50 ml, 2.9 mmol) was added thereto. After removal of the solvent in vacuum, the resulting crude product was washed with hexane and acetonitrile to obtain compound 61 as a yellow solid (yield of 96%: 948 mg, 1.44 mmol). The result for compound 61 measured by ¹H NMR (400 MHz, CDCl₃) was as follows:

[0148] δ8.54 (s, 2H), δ8.35-7.32 (m, 2H), δ7.85 (d, *J*=7.2 Hz, 2H), δ7.73-7.70 (m, 2H), δ7.52 (d, *J*=7.6 Hz, 2H), δ7.45-7.40 (m, 6H), δ7.33 (ddd, *J*=7.6, 7.6, 1.2 Hz, 2H), δ6.71 (dd, *J*=8.4, 1.6 Hz, 2H), δ6.34 (d, *J*=8.4 Hz, 2H), δ6.23 (d, *J*=2.0 Hz, 2H), and δ1.96 (s, 6H).

[0149] A [M]⁺ value of compound 61 measured by matrix assisted laser desorption/ionization-time of flight mass spectrometry (MALDI-TOF MS) measurement was 659.13 (m/z).

[0150] 1-2. Synthesis of Compound 81

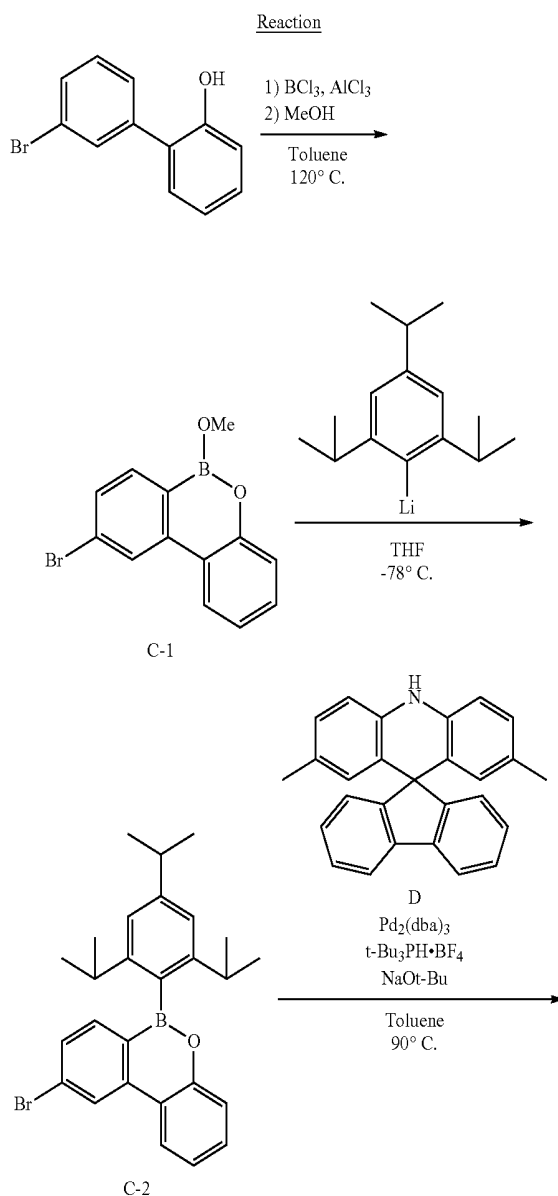

-continued

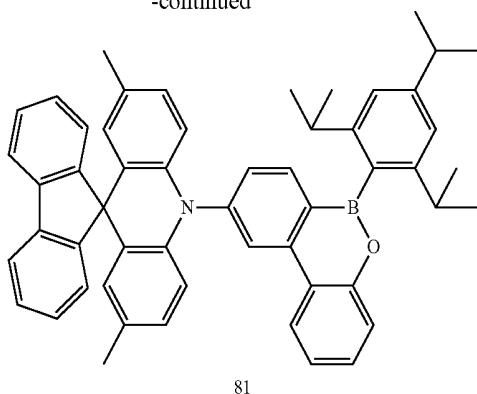
**[0151]** Synthesis of Intermediate C-1

[0152] BCl_3 (1.0 M, 6.0 ml, 6.0 mmol, in heptane) was added to anhydrous toluene (30 ml) under nitrogen atmosphere, and 3'-bromo-biphenyl-2-ol (996 mg, 4.00 mmol) mixed with anhydrous toluene (8 ml) was dripped thereto. The reaction mixture was heated to room temperature, and thereafter, AlCl_3 (60 mg, 0.45 mmol) was added. Then, the reaction mixture was stirred at 120° C. for 15 hours, and methanol (4 ml) was added thereto at 0° C. After removal of the solvent in vacuum, the resulting crude product was filtered in anhydrous CH_2Cl_2 . The filtrate was concentrated under reduced pressure, and then the resulting crude product was washed with methanol to obtain intermediate C-1 as a brown solid (yield of 81%: 934 mg, 3.23 mmol). The resulting crude product was utilized in the subsequent (e.g., next) reaction without additional purification.

[0153] Synthesis of Intermediate C-2

[0154] 1-bromo-2,4,6-triisopropylbenzene was added to anhydrous tetrahydrofuran (20 ml), and n-BuLi (1.57 M, 2.57 ml, 4.03 mmol, in hexane) was added thereto at -78° C. The reaction mixture was stirred at the same temperature for 1 hour, and intermediate C-1 (934 mg, 3.23 mmol, in anhydrous THF) was added thereto. The reaction mixture was heated to 0° C., and thereafter slowly heated to room temperature. After addition of water, the product was extracted with ethyl acetate. The extracted organic layer was washed with brine, dried over anhydrous Na_2SO_4 , and concentrated under reduced pressure. Then, the resulting crude product was purified by silica gel column chromatography (utilizing hexane and toluene at a volume ratio of 4:1 as an eluent) and re-precipitated from hexane and ethanol to obtain intermediate C-2 as a white solid (yield of 29%: 528 mg, 1.14 mmol). The result for intermediate C-2 measured by ^1H NMR (400 MHz, CDCl_3) was as follows:

[0155] δ 8.46 (s, 1 H), δ 8.24 (d, $J=7.6$ Hz, 1 H), δ 7.69 (d, $J=8.4$ Hz, 1 H), δ 7.56-7.51 (m, 3H), δ 7.07 (s, 2H), δ 2.96 (sept, $J=6.4$ Hz, 1 H), δ 2.54 (sept, $J=6.4$ Hz, 2H), δ 1.32 (d, $J=7.2$ Hz, 6H), δ 1.19 (d, $J=6.8$ Hz, 6H), and δ 1.08 (d, $J=6.8$ Hz, 6H).

[0156] Synthesis of Compound 81

[0157] A mixture of intermediate C-2 (162 mg, 0.351 mmol), D (127 mg, 0.351 mmol), $\text{Pd}_2(\text{dba})_3$ (6.8 mg, 0.0076 mmol), $\text{P}(\text{t-Bu})_3\text{H}\cdot\text{BF}_4$ (8.9 mg, 0.031 mmol), and sodium tert-butoxide (NaOt-Bu ; 51 mg, 0.531 mmol) was added to toluene (3.5 mL) under nitrogen atmosphere, and the mixture was stirred at 90° C. for 16 hours. Then, water was added thereto, and the product was extracted with toluene. The extracted organic layer was washed with brine, dried

over anhydrous Na_2SO_4 , and concentrated under reduced pressure. The resulting crude product was purified by silica gel column chromatography (utilizing hexane and toluene at a volume ratio of 3:1 as an eluent) and re-precipitated from CH_2Cl_2 and methanol to obtain compound 81 as a white solid (yield of 65%: 169 mg, 0.228 mmol). The result for compound 81 measured by ^1H NMR (400 MHz, CDCl_3) was as follows:

[0158] δ 8.43 (s, 1 H), δ 8.29 (d, $J=8.0$ Hz, 1 H), δ 8.15 (d, $J=8.4$ Hz, 1 H), δ 7.83 (d, $J=7.6$ Hz, 2H), δ 7.60-7.36 (m, 8H), δ 7.29 (d, $J=7.6$ Hz, 2H), δ 7.13 (s, 2H), δ 6.72 (d, $J=8.4$ Hz, 2H), δ 6.30 (d, $J=8.4$ Hz, 2H), δ 6.21 (s, 2H), δ 2.99 (sept, $J=6.4$ Hz, 1 H), δ 2.71 (sept, $J=6.4$ Hz, 2H), δ 1.95 (s, 6H), δ 1.35 (d, $J=6.8$ Hz, 6H), δ 1.28 (d, $J=6.4$ Hz, 6H), and δ 1.19 (d, $J=6.4$ Hz, 6H).

[0159] A [M]⁺ value of compound 81 measured by matrix assisted laser desorption/ionization-time of flight mass spectrometry (MALDI-TOF MS) measurement was 739.45 (m/z).

[0160] 2. Manufacture and Evaluation of Polycyclic Compound and Organic Electroluminescence Device Including the Polycyclic Compound

[0161] 2-1. Energy Level of the Polycyclic Compound

[0162] Lowest singlet (S1) energy levels and lowest triplet (T1) energy levels of the compounds 43, 61, and 81 in Examples and X-1, X-2, and X-3 in Comparative Examples were measured (e.g., calculated) by a nonempirical molecular orbital method. For example, the calculation was performed by utilizing the Gaussian09 software package from Gaussian, Inc., and applying density functional theory (DFT) utilizing the B3LYP hybrid functional for a general function and the 6-31G(d) basis set for a base function.

COMPOUNDS IN EXAMPLES

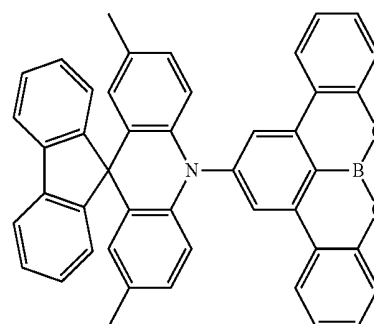
[0163]

43

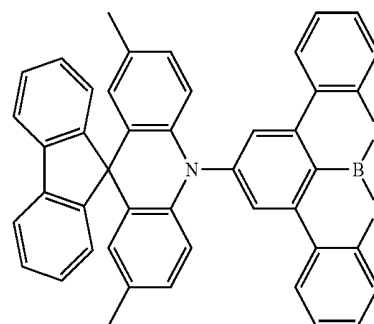

61

-continued

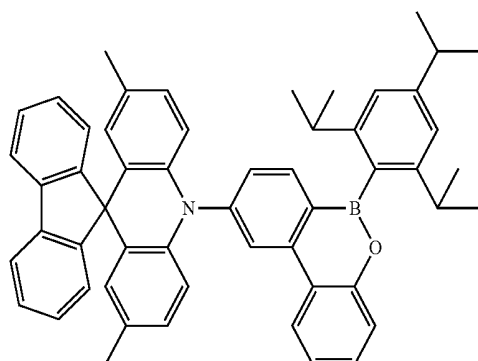

81

COMPOUNDS IN COMPARATIVE EXAMPLES

[0164]

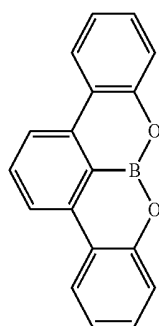

X-1

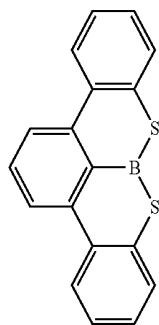

X-2

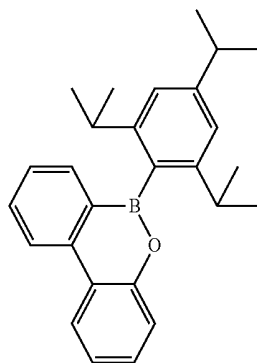

X-3

TABLE 1

Compound	S1 energy level	T1 energy level	ΔE_{ST}
Compound 43 in Example	2.79	2.75	0.04
Compound 61 in Example	2.55	2.55	0.00
Compound 81 in Example	2.77	2.76	0.01
Compound X-1 in Comparative Example	3.78	2.83	0.95
Compound X-2 in Comparative Example	3.53	2.82	0.71
Compound X-3 in Comparative Example	3.84	3.10	0.74

[0165] In Table 1, ΔE_{ST} represents a difference value between a lowest singlet energy level and a lowest triplet energy level. The S1 and T1 energy level units are eV. The ΔE_{ST} values of the compounds in Examples are about 0.00-0.04 eV, and the ΔE_{ST} values of the compounds in Comparative Examples are about 0.71-0.95 eV. Accordingly, it was found that the compounds in Examples have lower ΔE_{ST} values than the compounds in Comparative Examples. Therefore, all the compounds in Examples may be more suitable as thermally activated delayed fluorescence materials than the compounds in Comparative Examples, and all the compounds in Examples may emit highly efficient (e.g., very efficiently emit) thermally activated delayed fluorescence.

[0166] Evaluation of Fluorescence Emission Characteristics

[0167] A JASCO V-670 spectrometer was utilized for evaluation of fluorescence emission characteristics. For measuring the compounds in Examples, a film was formed on quartz glass by doping PPF with 20 wt% of the compound of Example or Comparative Example, and a fluorescence emission spectrum thereof was measured. For the fluorescence emission spectrum of the comparative example compounds, known data were described. A fluorescence quantum yield of Example and Comparative example was measured utilizing a JASCO ILF-835 integrating sphere system. A value based on the CIE 1931 color space was utilized as a Z stimulus value in the CIE tristimulus values of the CIE color matching functions at each maximum emission wavelength, and when the wavelength was 360 nm or less, the value at the 360 nm wavelength was utilized as a Z stimulus value. A blue fluorescence efficiency index was defined as multiplication of the fluorescence quantum yield and the Z stimulus value at each maximum emission wavelength, and relative luminous efficiency of each material was compared.

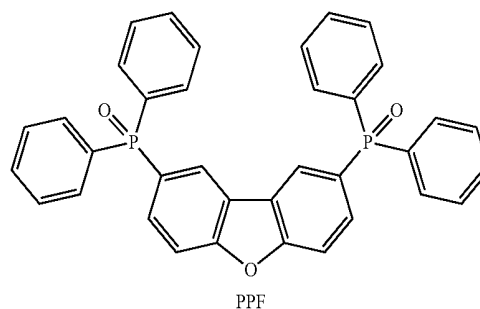

PPF

TABLE 2

Compound	λ max (nm)	Fluorescence quantum yield (%)	Z stimulus value (in λ max)	Blue fluorescence efficiency index (in λ max)
Compound 43 in Example	461	28	1.65	4.61×10
Compound 61 in Example	491	81	4.40×10^{-1}	3.56×10
Compound 81 in Example	458	53	1.71	9.04×10
Compound X-1 in Comparative Example	335	60	6.06×10^{-4}	3.64×10^{-2}
Compound X-3 in Comparative Example	341	35	6.06×10^{-4}	2.12×10^{-2}

[0168] In Table 2, the blue fluorescence efficiency indices of the compounds in Examples were about 3.56×10 to 9.04×10 , and the blue fluorescence efficiency indices of the compounds in Comparative Examples X-1 and X-3 were 3.64×10^{-2} and 2.12×10^{-2} , respectively. Accordingly, the compounds in Examples have higher blue relative luminous efficiency than the compounds in Comparative Examples, and thus, when the compounds in Examples are utilized as blue light emission materials in applications such as display devices, high-efficiency may be achieved.

[0169] Manufacture of Organic Electroluminescence Devices

[0170] The organic electroluminescence devices in Examples 1 to 3 were manufactured by utilizing the compounds 43, 61, and 81 in Examples as dopant materials in the emission layer.

[0171] In the organic electroluminescence devices in Examples 1 to 3, a first electrode EL1 having a thickness of about 1500 Å was formed with ITO, cleaned with ultrapure water, and subjected to UV ozone treatment for 10 minutes. A hole injection layer HIL having a thickness of about 400 Å was formed with NPB, and an emission layer EML having a thickness of 200 Å was formed with PPF doped with the compounds in Examples at a ratio of 20%, respectively. A hole blocking layer HBL having a thickness of 100 Å was formed with PPF, an electron transport layer ETL having a thickness of 300 Å was formed with TPBi, and an electron injection layer EIL having a thickness of 10 Å was formed with Liq. A second electrode EL2 having a thickness of 1000 Å was formed with Al. Each layer was formed by a vacuum deposition method utilizing vacuum deposition apparatus.

[0172] Evaluation of Characteristics of Organic Electroluminescence Devices

[0173] To evaluate characteristics of the organic electroluminescence devices according to Examples and Comparative Examples, maximum values of external quantum efficiency were evaluated. A voltage and current density of the organic electroluminescence device were measured utilizing a source meter (2400 series manufactured by Keithley Instruments), and luminance and external quantum efficiency were measured utilizing external quantum efficiency measuring apparatus C9920-12 manufactured by Hamamatsu Photonics.

TABLE 3

Device manufacturing example	Emission layer dopant	λ max (nm)	EQE max (%)	Maximum current efficiency (cd/A)
Example 1	compound 43	471	5.2	9.1
Example 2	compound 61	489	20.9	46.7
Example 3	compound 81	459	13.3	16.1

[0174] Referring to the results in Table 3, each of the devices in Examples 1 to 3 emits deep blue light or blue green light in a wavelength range of about 459-489 nm, and thus, the devices in Examples are more suitable for usage as blue light emission materials when compared with the devices in Comparative Examples, which emit light in the ultraviolet or violet wavelength range (referring to Table 2). In addition, the devices in Examples 1 to 3 have external quantum efficiencies of about 5.2-20.9% and maximum current efficiencies of about 9.1-46.7 cd/A, and thus, it was found that the devices in Examples have high efficiency characteristics when compared with other fluorescent light emission materials which generally have external quantum efficiencies of about 5% or less. For example, the devices in Examples 2 and 3 have external quantum efficiencies of 13.3% and 20.9% respectively, and thus, these devices have excellent luminescence efficiencies.

[0175] A polycyclic compound according to an embodiment of the present disclosure includes an electron donor represented by Formula 1 and an electron acceptor represented by Formula 2-1 or Formula 2-2. Distortion in the molecular structure occurs due to steric characteristics of the electron donor represented by Formula 1 and the electron acceptor represented by Formula 2-1 or Formula 2-2, and the highest occupied molecular orbital (HOMO) and the lowest unoccupied molecular orbital (LUMO) are separated. The separation of the HOMO and LUMO leads to reduced ΔE_{ST} , and as a result, reverse intersystem crossing is likely to occur, so that the polycyclic compound of an embodiment may function as a thermally activated delayed fluorescent material.

[0176] Furthermore, each of Formula 2-1 and Formula 2-2 includes a structure of borinate ester (Formula 2-1) or boronate ester (Formula 2-2) in which B, which is an electron accepting atom, is directly bonded to O or S, which is an electron donating atom, and thus, the electron deficiency of B is relaxed (e.g., compensated) by O or S, so that the polycyclic compound may function as a thermally activated delayed fluorescent material which emits light in the blue wavelength range.

[0177] A polycyclic compound of an embodiment includes an electron donor and an electron acceptor bonded to the electron donor. The electron donor may contain an acridine derivative or a dibenzo-azasiline derivative. The electron acceptor may contain B as a ring-forming atom, O or S directly bonded to B, and may also contain a heterocyclic group in which three or five hexagonal rings are condensed.

[0178] An organic electroluminescence device including a polycyclic compound according to an embodiment of the present disclosure may achieve high efficiency.

[0179] A polycyclic compound according to an embodiment of the present disclosure may be applied to an organic electroluminescence device to contribute to high efficiency.

[0180] Expressions such as “at least one of” or “at least one selected from” when preceding a list of elements, modify the entire list of elements and do not modify the individual elements of the list. Further, the use of “may” when describing embodiments of the present disclosure refers to “one or more embodiments of the present disclosure.” Also, the term “exemplary” is intended to refer to an example or illustration.

[0181] As used herein, the term “substantially,” “about,” and similar terms are used as terms of approximation and not as terms of degree, and are intended to account for the inherent deviations in measured or calculated values that would be recognized by those of ordinary skill in the art. Moreover, any numerical range recited herein is intended to include all sub-ranges of the same numerical precision subsumed within the recited range. For example, a range of “1.0 to 10.0” is intended to include all subranges between (and including) the recited minimum value of 1.0 and the recited maximum value of 10.0, that is, having a minimum value equal to or greater than 1.0 and a maximum value equal to or less than 10.0, such as, for example, 2.4 to 7.6. Any maximum numerical limitation recited herein is intended to include all lower numerical limitations subsumed therein and any minimum numerical limitation recited in this specification is intended to include all higher numerical limitations subsumed therein.

[0182] Accordingly, Applicant reserves the right to amend this specification, including the claims, to expressly recite any sub-range subsumed within the ranges expressly recited herein. All such ranges are intended to be inherently described in this specification such that amending to expressly recite any such subranges would comply with the requirements of 35 U.S.C. § 112, first paragraph, or 35 U.S.C. § 112(a), and 35 U.S.C. § 132(a).

[0183] Although the exemplary embodiments of the present disclosure have been described, it is understood that the present disclosure should not be limited to these exemplary embodiments but various changes and modifications can be made by one ordinary skilled in the art within the spirit and scope of the present disclosure as hereinafter claimed, and equivalents thereof.

What is claimed is:

1. An organic electroluminescence device comprising:
 - a first electrode;
 - a second electrode on the first electrode; and
 - a plurality of organic layers between the first electrode and the second electrode, and comprising an emission layer,
 wherein the emission layer comprises a polycyclic compound comprising an electron donor and an electron acceptor bonded to the electron donor,
 - the electron donor comprises an acridine derivative or a dibenzo-azasiline derivative, and
 - the electron acceptor comprises B as a ring-forming atom, O or S directly bonded to B, and a heterocyclic group in which three or five hexagonal rings are condensed.
2. The organic electroluminescence device of claim 1, wherein the electron acceptor comprises a dibenzo-thiaborinine derivative or a dibenzo-oxaborinine derivative.
3. The organic electroluminescence device of claim 2, wherein the emission layer comprises a host and a dopant, and
 - the dopant comprises the polycyclic compound.

4. The organic electroluminescence device of claim 1, wherein a difference (ΔE_{ST}) between a lowest singlet energy level and a lowest triplet energy level of the polycyclic compound is 0.2 eV or less.

5. The organic electroluminescence device of claim 1, wherein the emission layer is to emit light in a wavelength range of 440-500 nm.

6. The organic electroluminescence device of claim 1, wherein the electron donor is represented by Formula 1, and the electron acceptor is represented by Formula 2-1 or Formula 2-2:

Formula 1

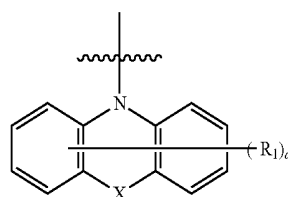

Formula 2-1

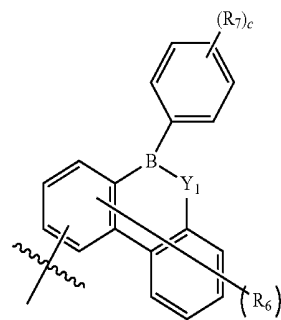

Formula 2-2

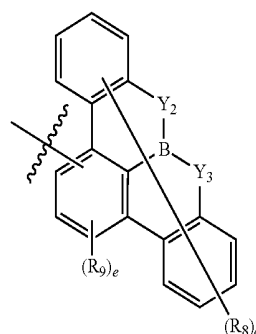

wherein in Formula 1,

R_1 is a hydrogen atom, a deuterium atom, a halogen atom, a substituted or unsubstituted silyl group, a substituted or unsubstituted amine group, a substituted or unsubstituted alkoxy group having 1 to 10 carbon atoms, a substituted or unsubstituted alkyl group having 1 to 20 carbon atoms, a substituted or unsubstituted aryl group having 6 to 20 ring-forming carbon atoms, or a substituted or unsubstituted heteroaryl group having 3 to 20 ring-forming carbon atoms,

a is an integer of 0 to 8,

X is CR_2R_3 or SiR_4R_5 ,

R_2 to R_5 are each independently a hydrogen atom, a deuterium atom, a halogen atom, a substituted or unsubstituted alkyl group having 1 to 20 carbon atoms, a substituted or unsubstituted aryl group having 6 to 20 ring-forming carbon atoms, or a substituted or unsub-

stituted heteroaryl group having 3 to 20 ring-forming carbon atoms, or are bonded with one or more adjacent groups to form a ring,

wherein in Formula 2-1 and in Formula 2-2,

Y_1 to Y_3 are each independently O or S,

R_6 to R_9 are each independently a hydrogen atom, a deuterium atom, a halogen atom, a substituted or unsubstituted alkoxy group having 1 to 10 carbon atoms, a substituted or unsubstituted sulfide group having 1 to 10 carbon atoms, a substituted or unsubstituted amine group, a substituted or unsubstituted silyl group, a substituted or unsubstituted alkyl group having 1 to 20 carbon atoms, a substituted or unsubstituted aryl group having 6 to 20 ring-forming carbon atoms, or a substituted or unsubstituted heteroaryl group having 3 to 20 ring-forming carbon atoms,

b is an integer of 0 to 7,

c is an integer of 0 to 5,

d is an integer of 0 to 8, and

e is an integer of 0 to 2.

7. The organic electroluminescence device of claim 6, wherein the polycyclic compound is represented by Formula 3-1 or Formula 3-2:

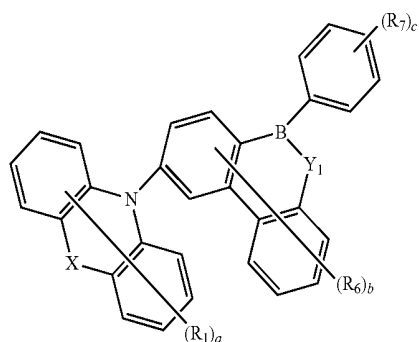

Formula 3-1

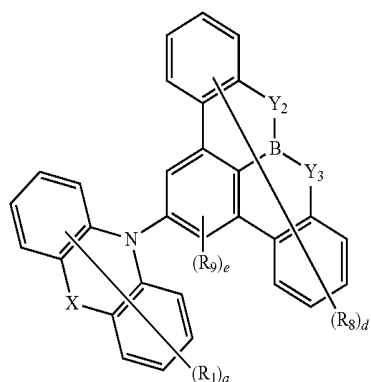

Formula 3-2

wherein in Formula 3-1 and Formula 3-2,

R_1 , X, Y_1 to Y_3 , R_6 to R_9 , and a to e are the same as respectively defined in connection with Formula 1, Formula 2-1, and Formula 2-2.

8. The organic electroluminescence device of claim 6, wherein the electron donor represented by Formula 1 is represented by Formula 4:

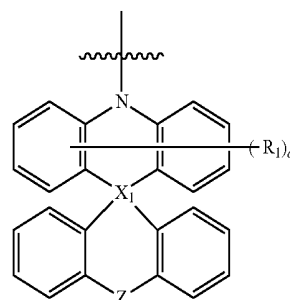

Formula 4

wherein in Formula 4,

X_1 is C or Si,

Z is a direct bond, O, or S, and

R_1 and a are the same as respectively defined in connection with Formula 1.

9. The organic electroluminescence device of claim 6, wherein Y_2 and Y_3 are the same.

10. The organic electroluminescence device of claim 6, wherein R_1 is a hydrogen atom, a fluorine atom, a methyl group, a t-butyl group, a substituted or unsubstituted arylamine group having 6 to 20 ring-forming carbon atoms, a substituted or unsubstituted phenyl group, a substituted or unsubstituted phenanthryl group, a substituted or unsubstituted thiophenyl group, a substituted or unsubstituted carbazolyl group, or a substituted or unsubstituted acridinyl group.

11. The organic electroluminescence device of claim 6, wherein R_2 to R_5 are each independently a methyl group or a substituted or unsubstituted phenyl group, or are bonded to one or more adjacent groups to form a dibenzospiro ring.

12. The organic electroluminescence device of claim 1, wherein the polycyclic compound comprises at least one of compounds represented in Compound Group 1:

Compound Group 1

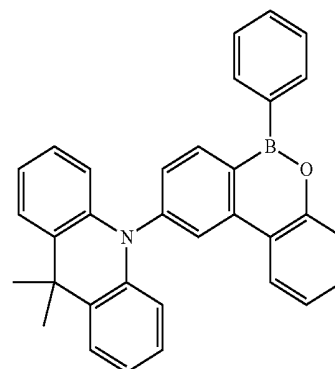

-continued

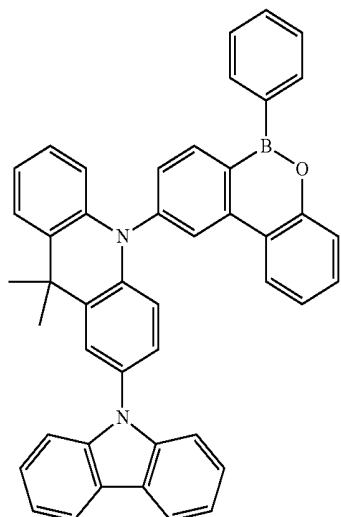
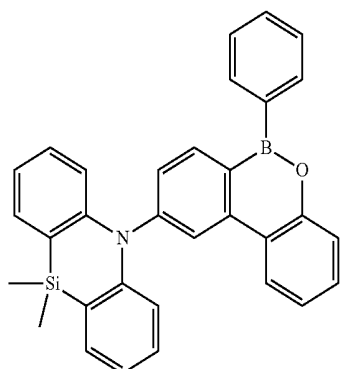
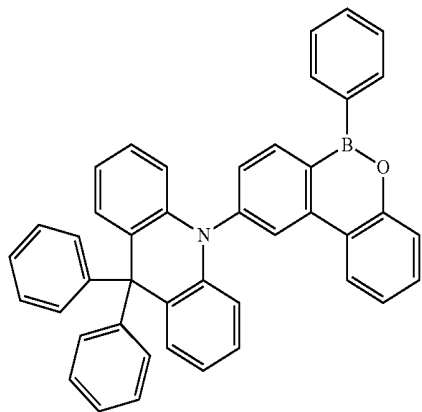

-continued

5

2

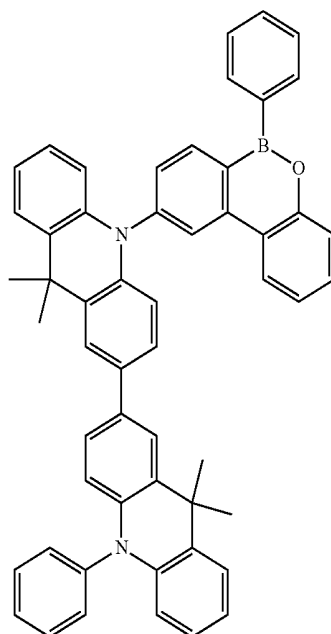

3

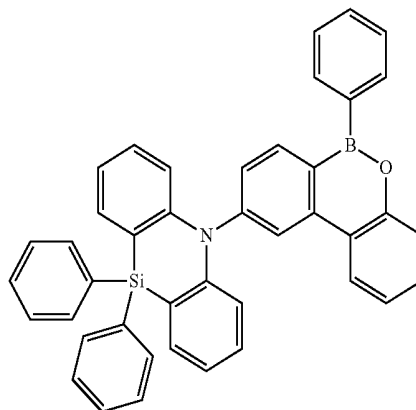

6

4

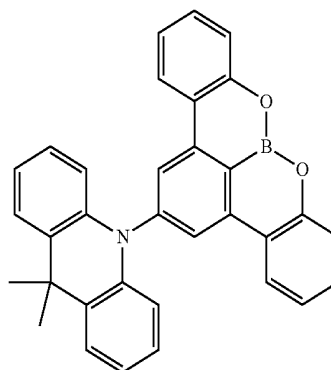

7

-continued

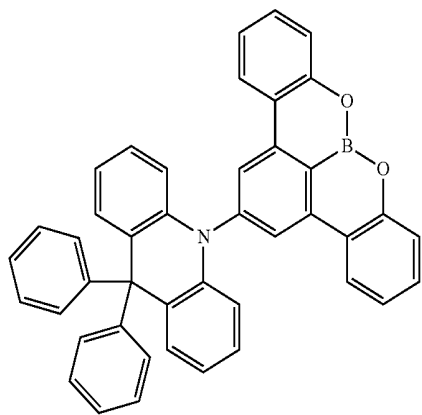

8

-continued

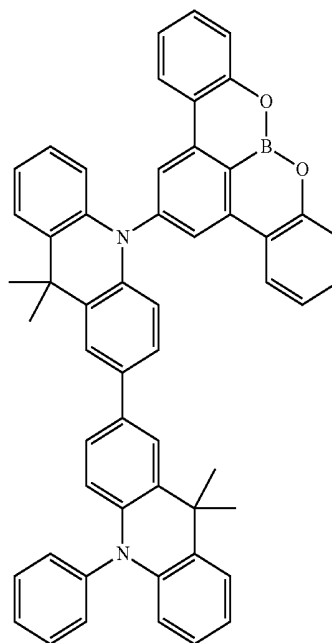

11

9

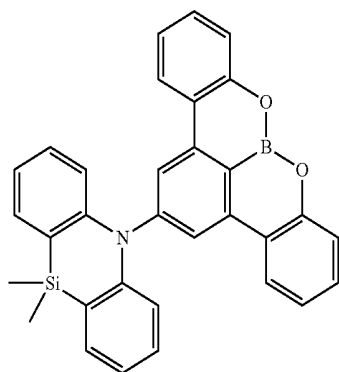

12

10

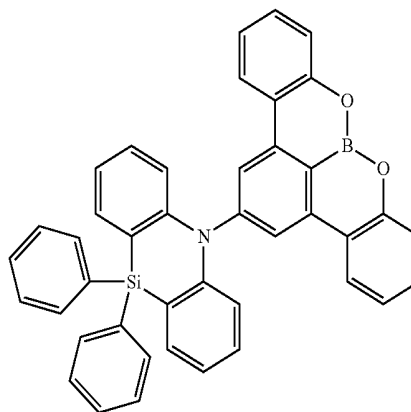

13

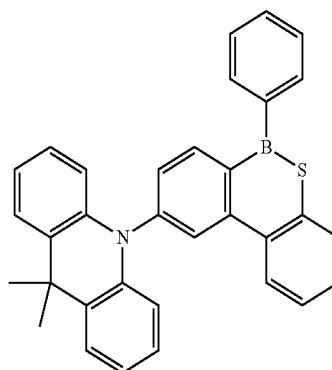
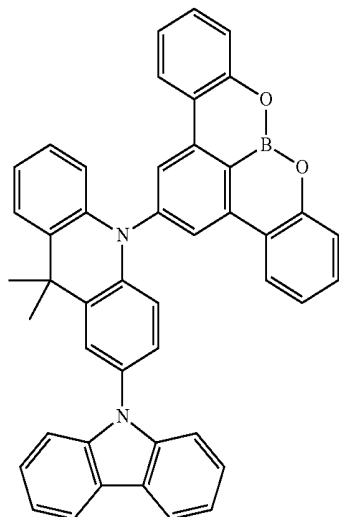

-continued

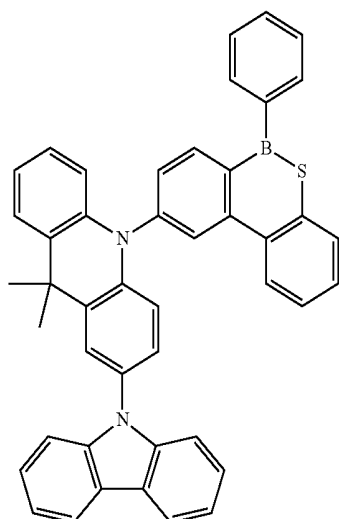
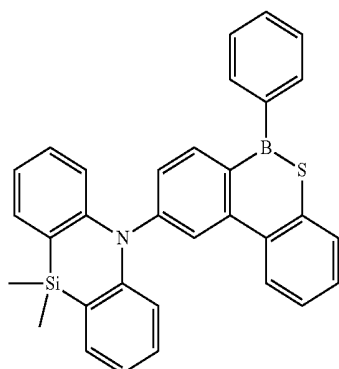
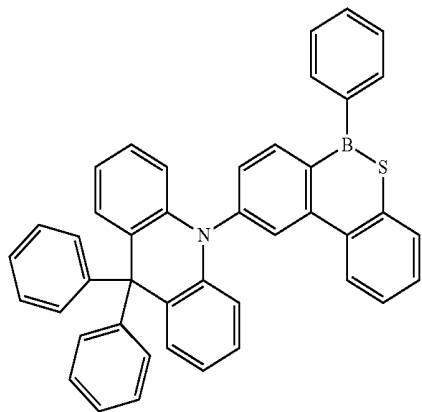

-continued

17

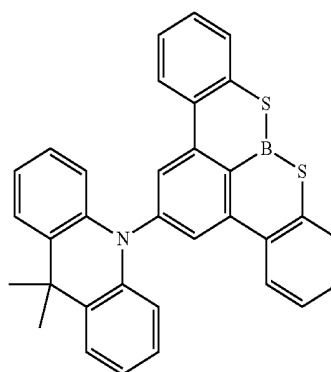
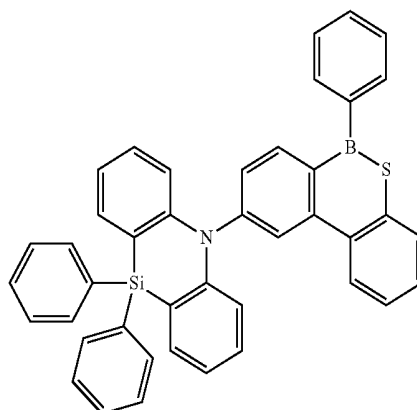
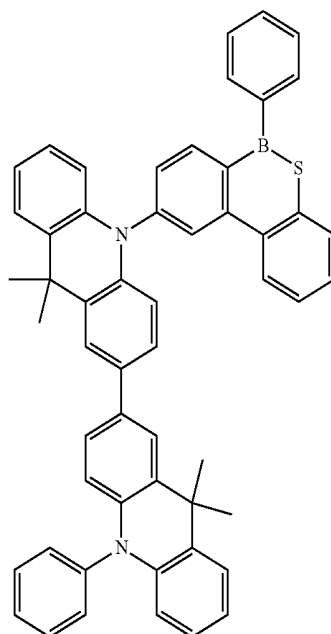

-continued

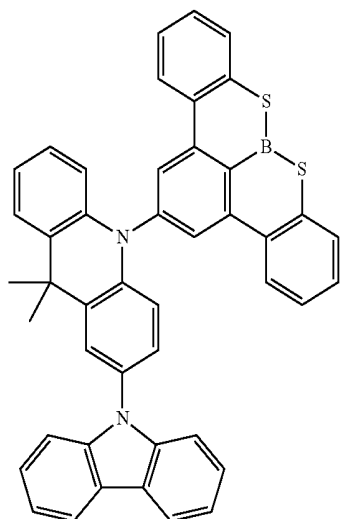
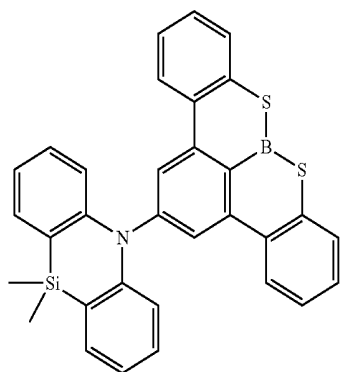
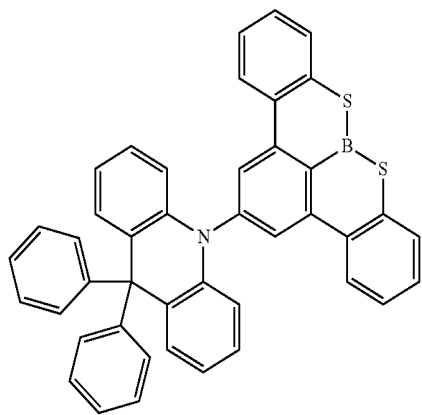

-continued

23

20

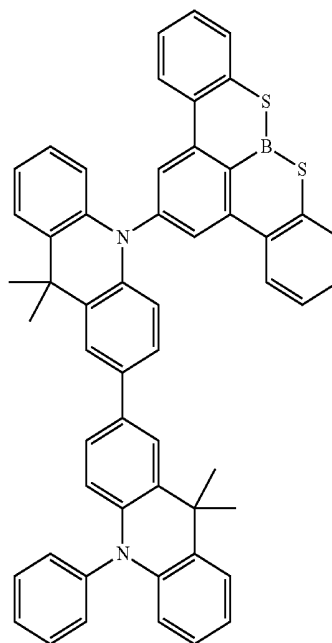

21

24

22

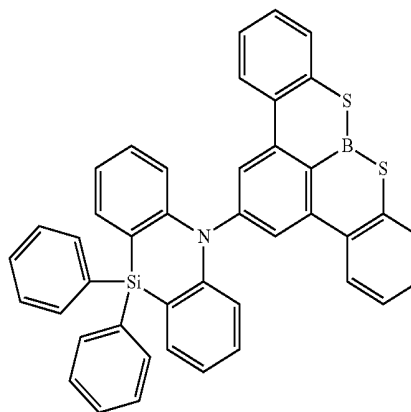

25

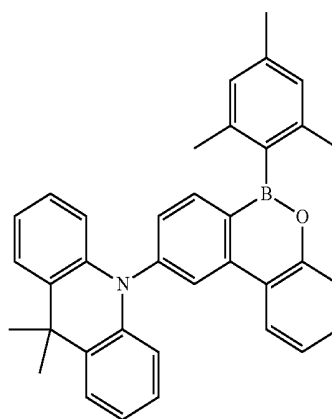

-continued

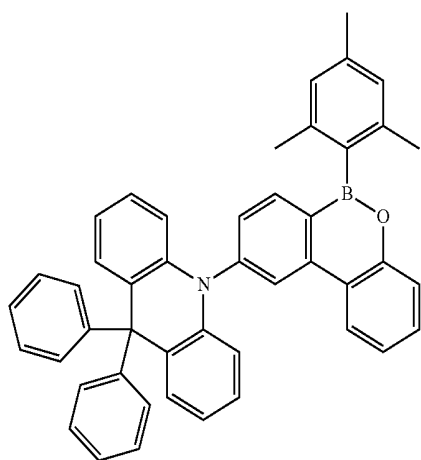

26

-continued

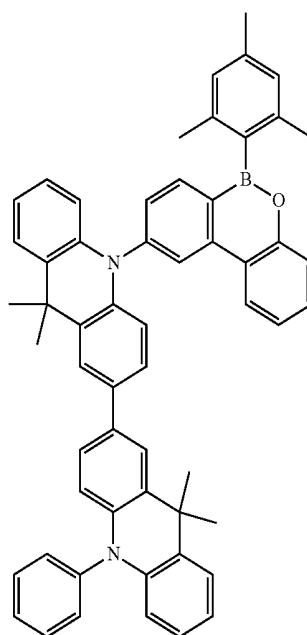

29

27

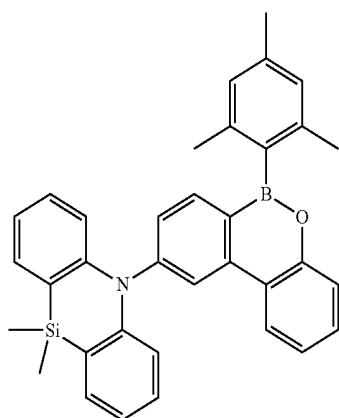

28

30

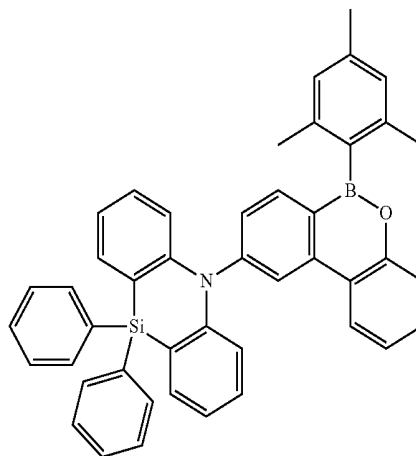

31

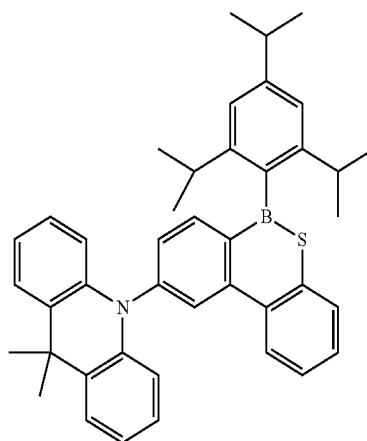
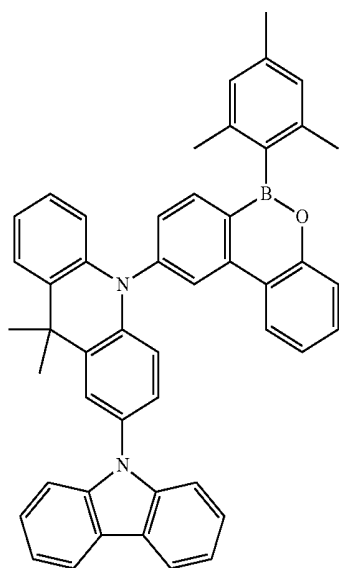

-continued

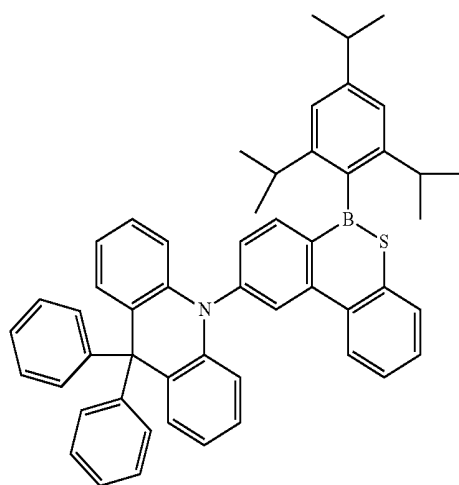

32

-continued

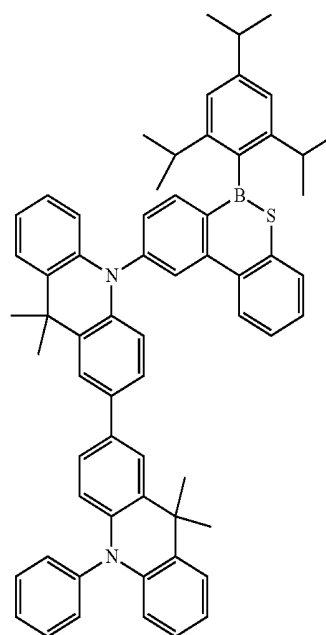

35

33

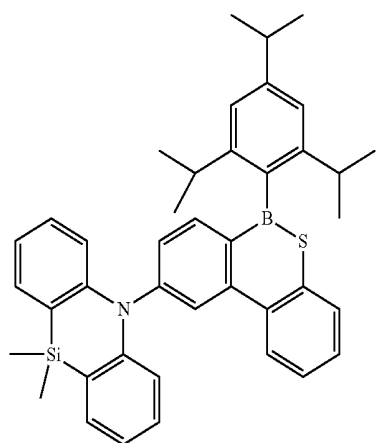

34

36

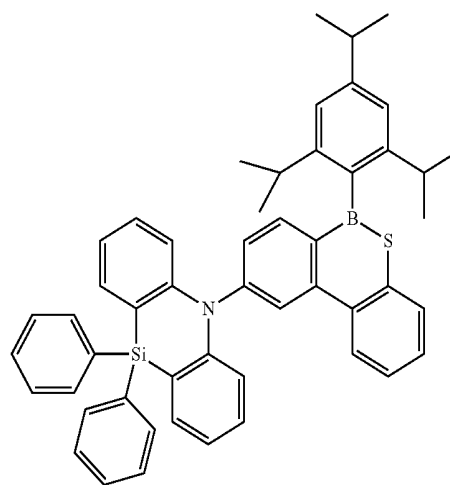

37

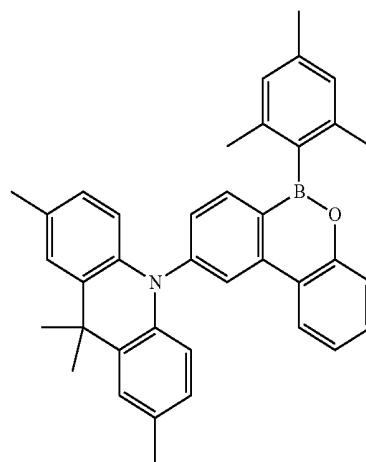
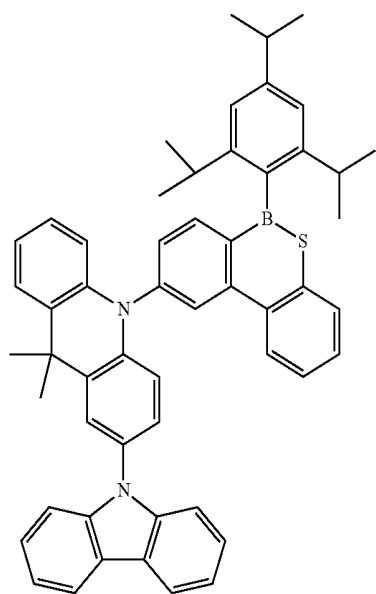

-continued

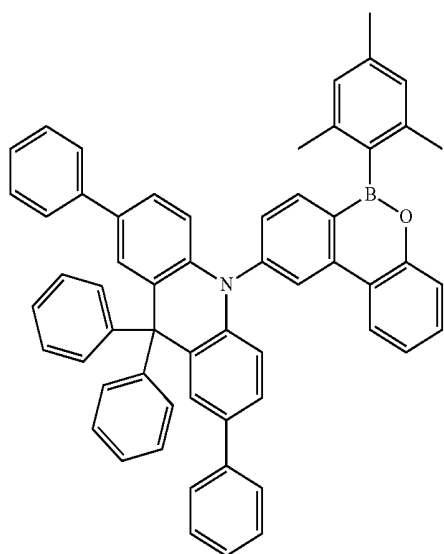

38

-continued

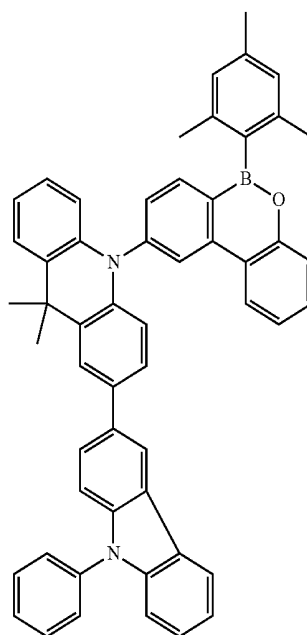

41

39

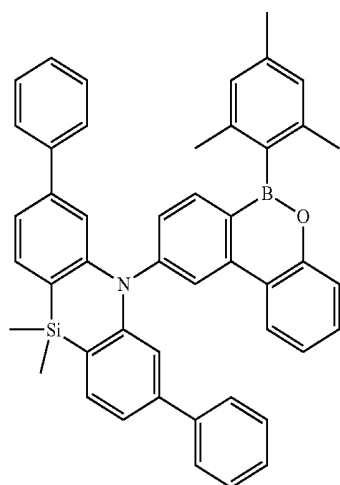

42

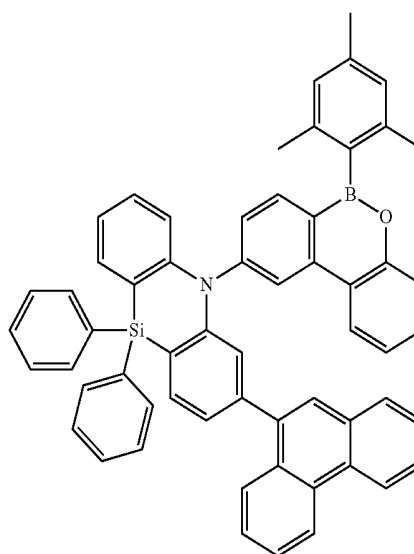

40

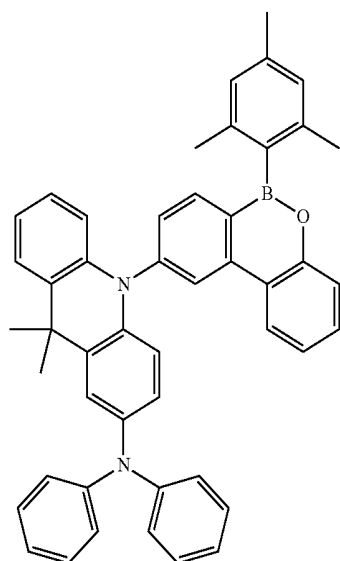

43

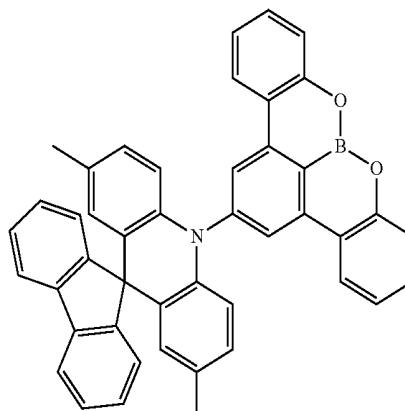

-continued

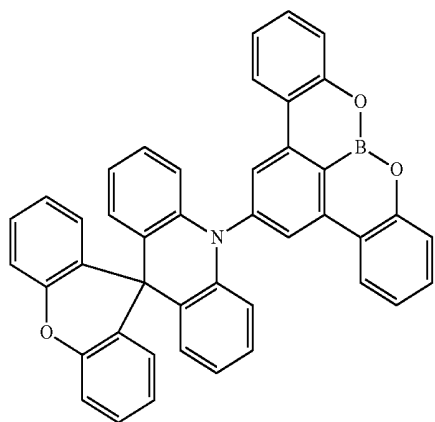

44

-continued

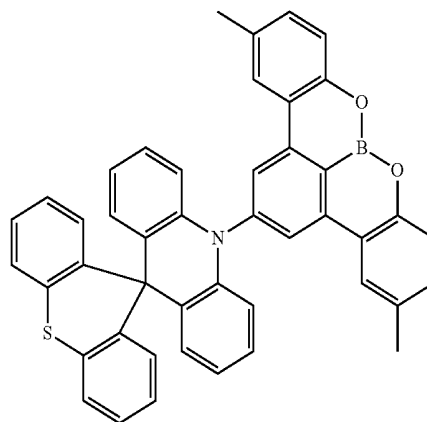

47

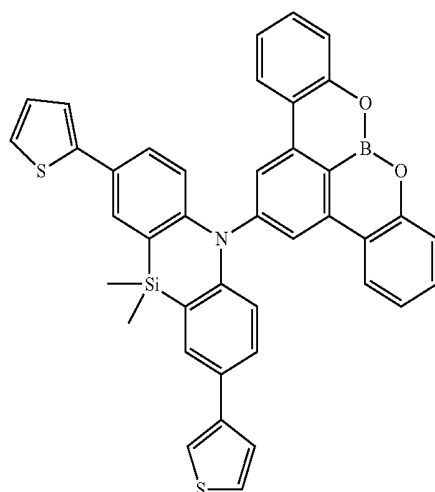

45

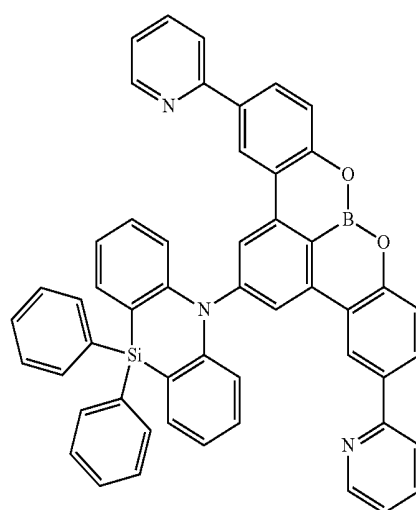

48

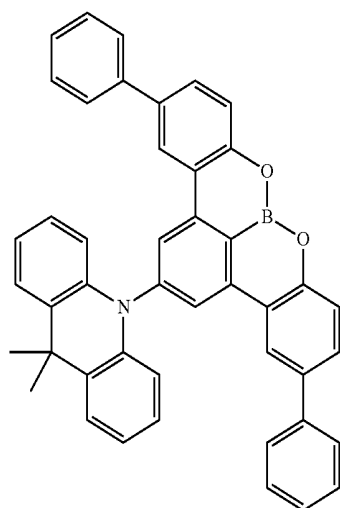

46

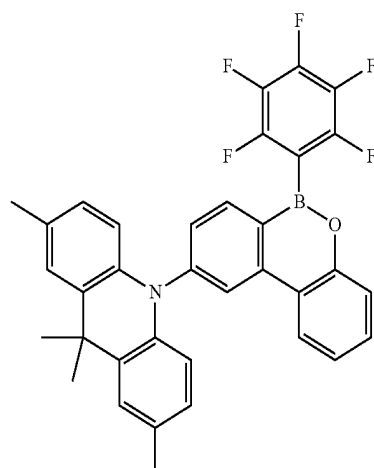

49

-continued

50

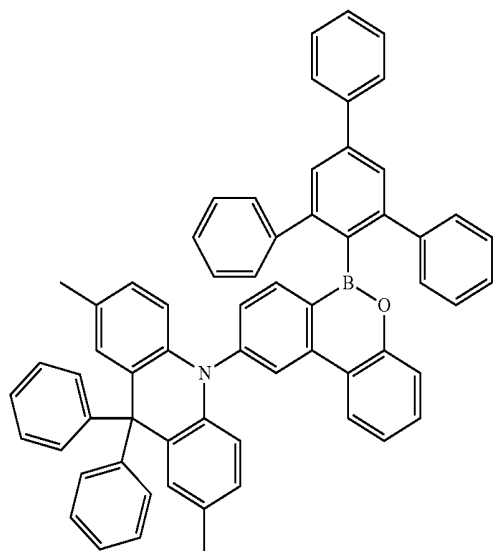

51

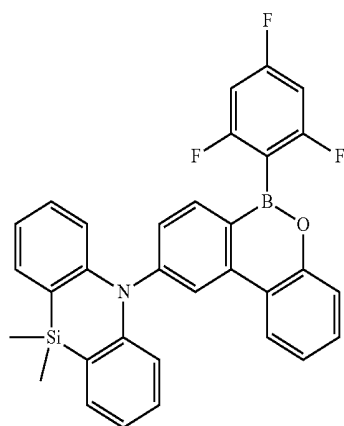

52

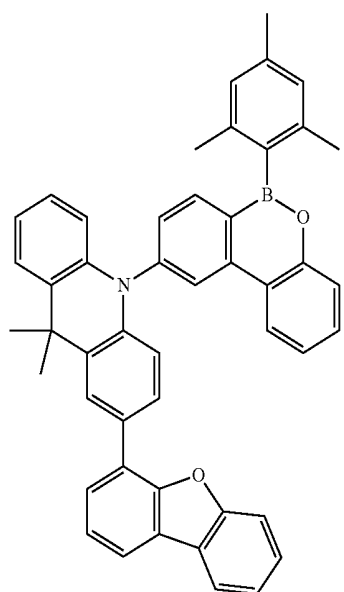

-continued

53

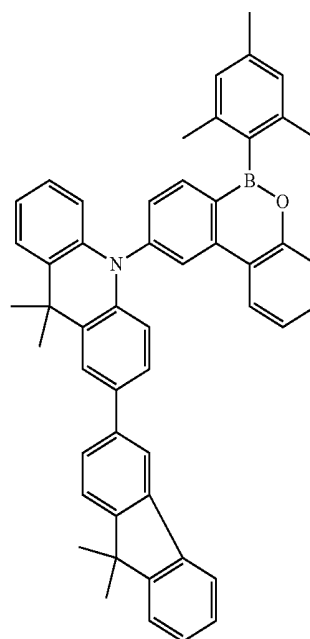

54

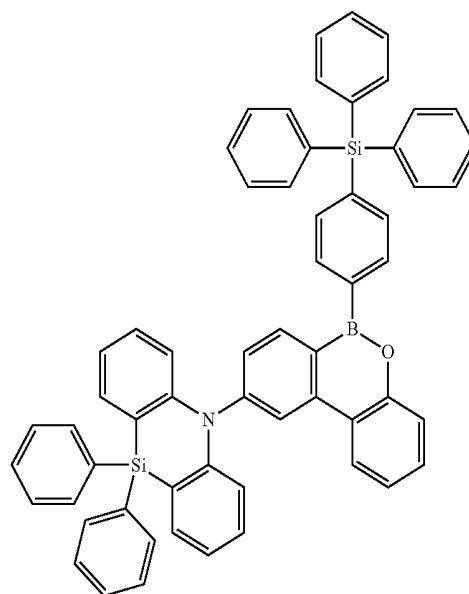

55

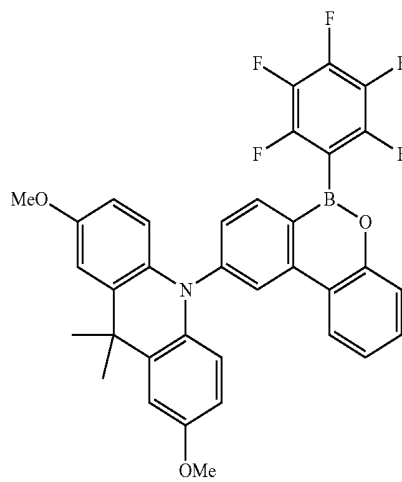

-continued

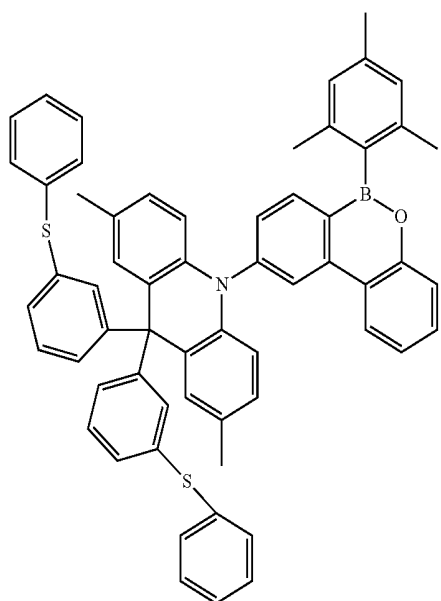

-continued

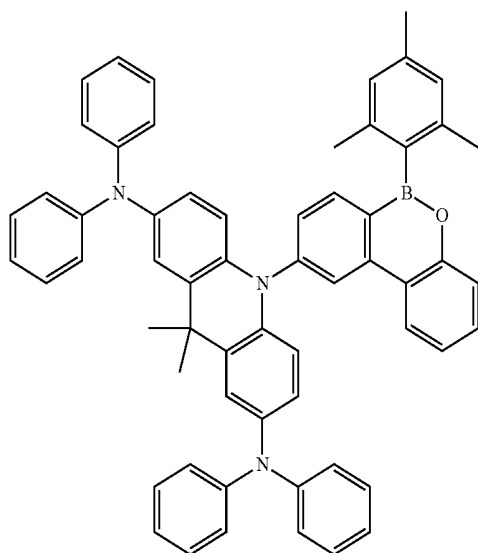
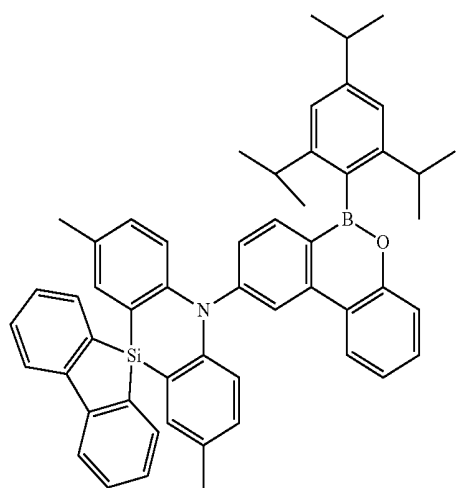
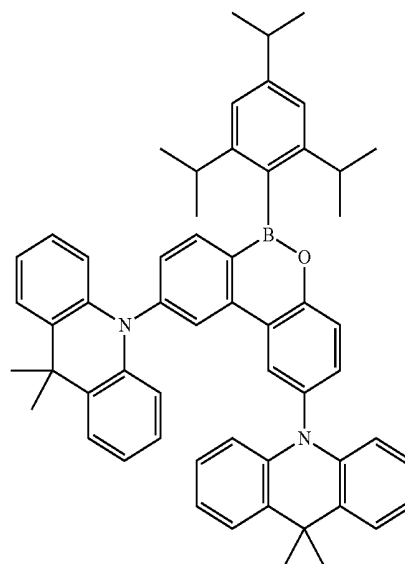

60

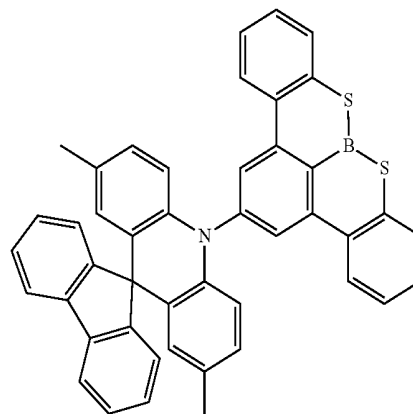

61

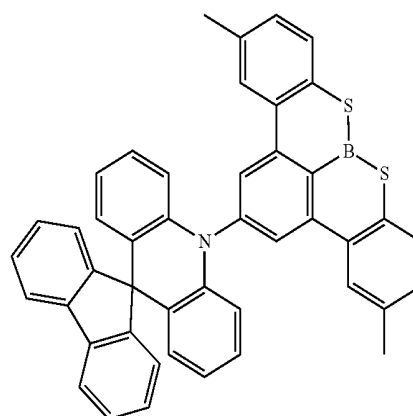

62

-continued

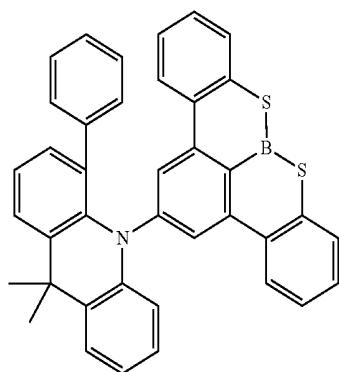

63

-continued

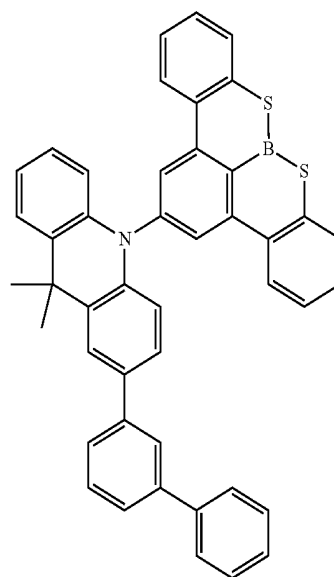

66

64

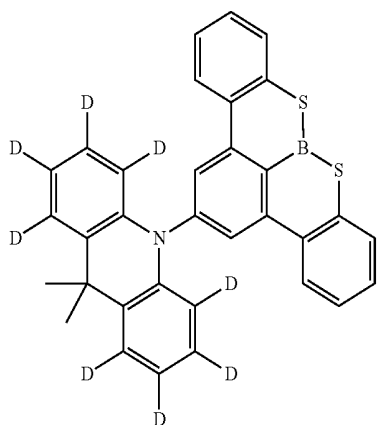

67

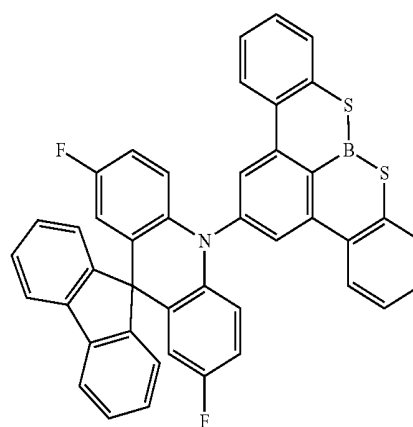

65

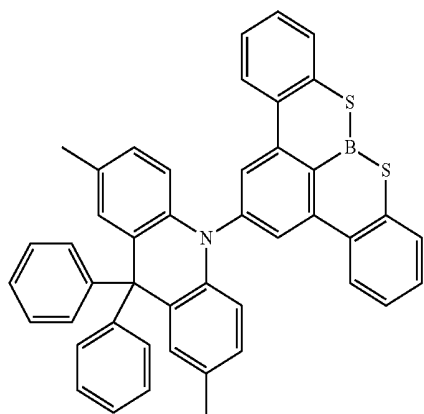

68

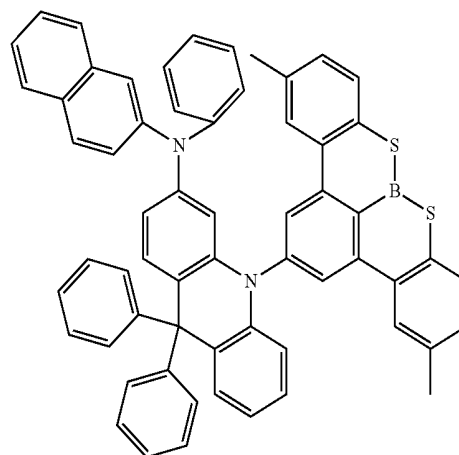

-continued

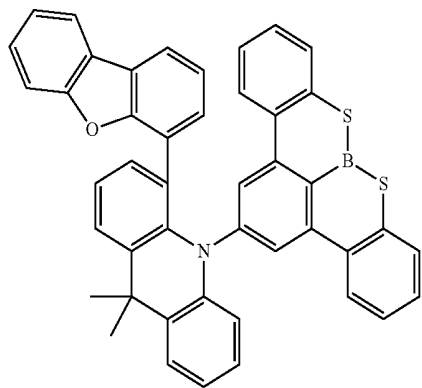

69

-continued

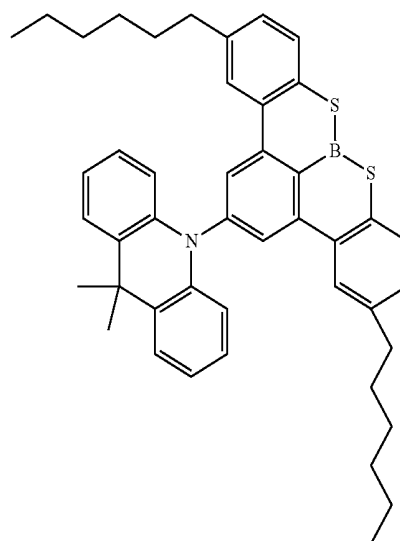

72

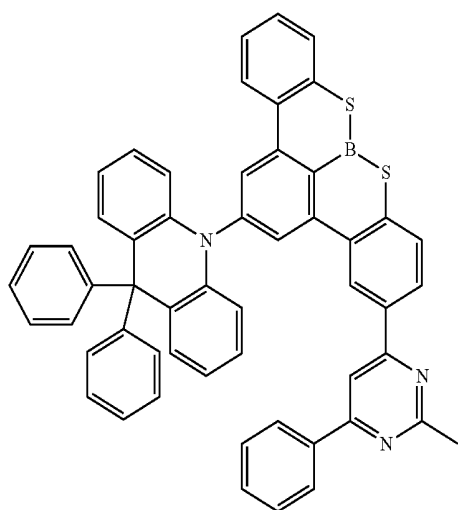

70

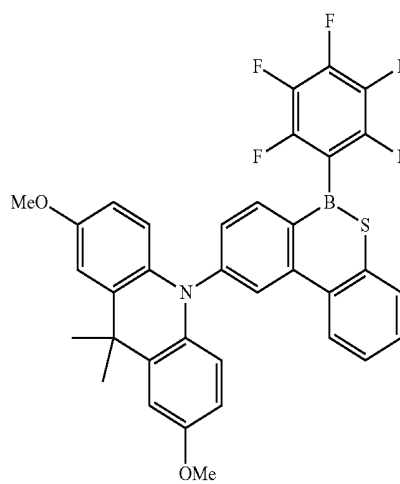

73

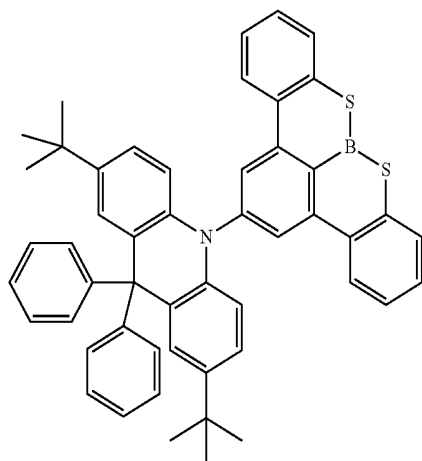

71

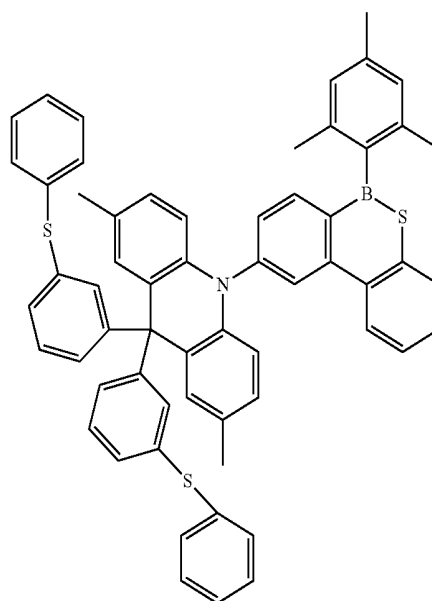

74

-continued

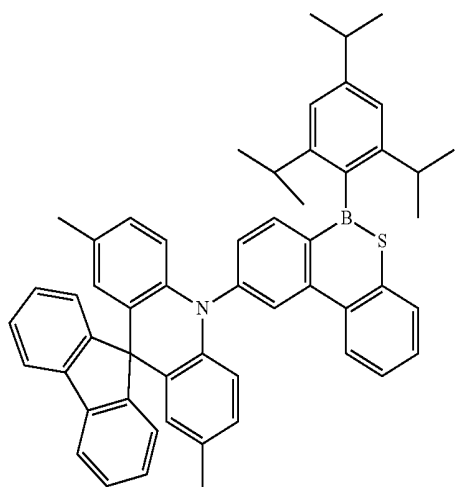

75

-continued

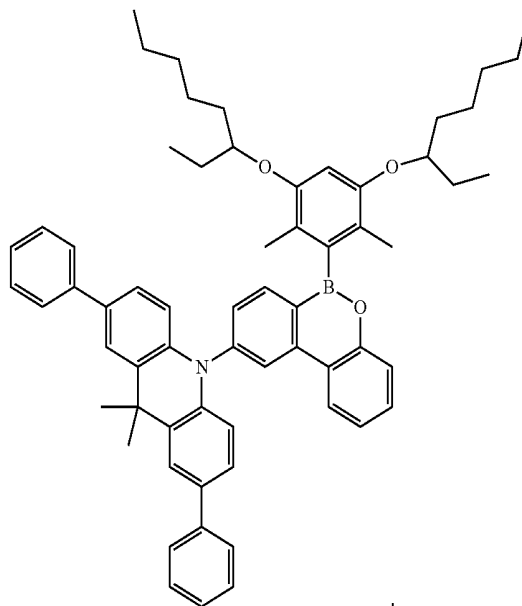

76

79

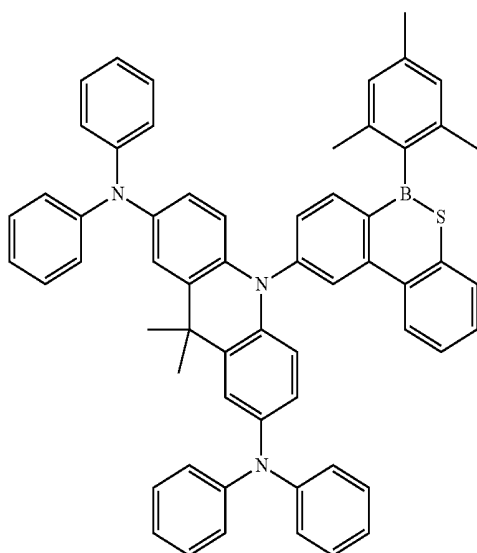

78

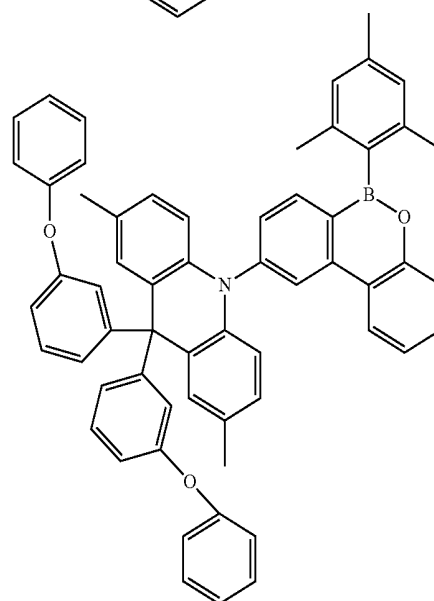

80

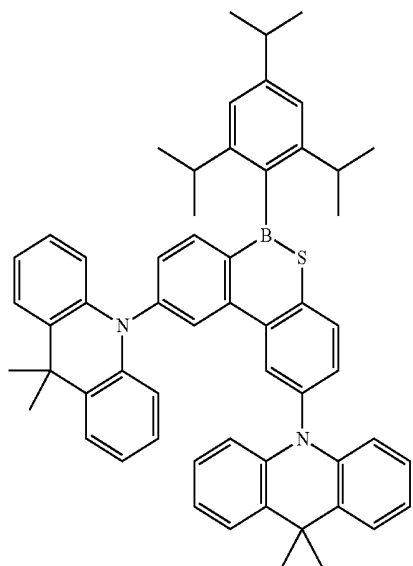

81

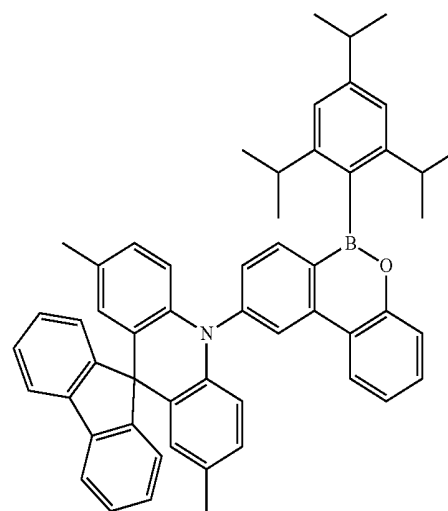

-continued

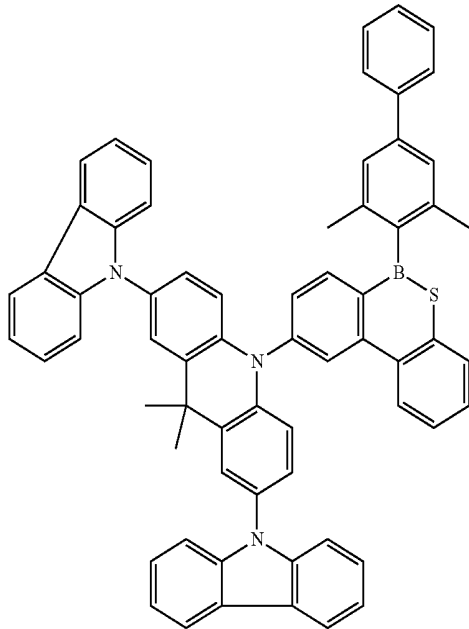

82

-continued

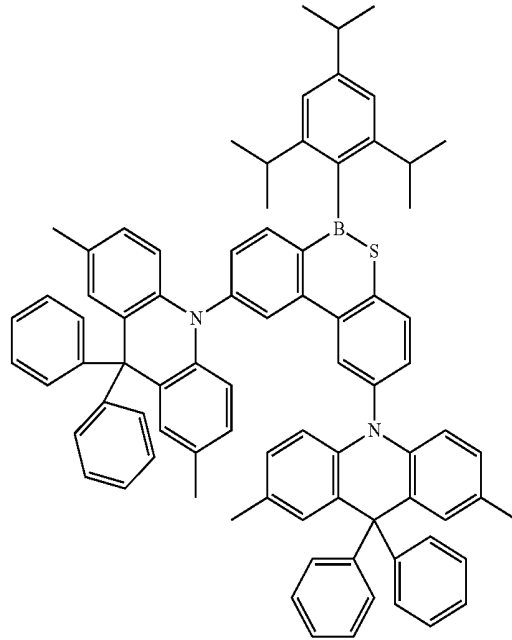

84

13. An organic electroluminescence device comprising:
 a first electrode;
 a second electrode on the first electrode; and
 a plurality of organic layers between the first electrode and the second electrode, and comprising an emission layer,
 wherein at least one organic layer of the plurality of organic layers comprises a polycyclic compound represented by Formula A:

DU-AU

Formula A

83

wherein in Formula A,
 DU is represented by Formula 1, and AU is represented by Formula 2-1 or Formula 2-2:

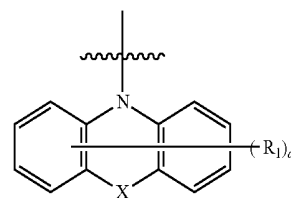
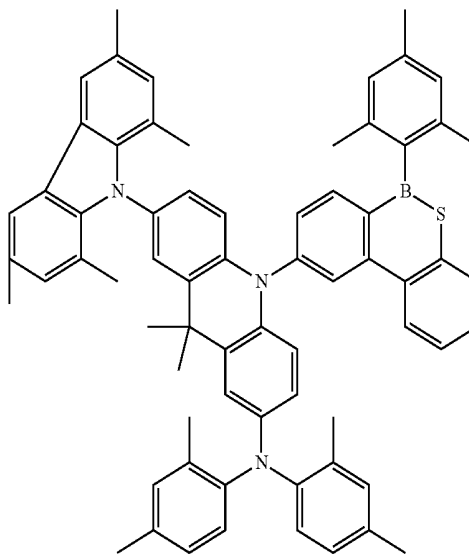

Formula 1

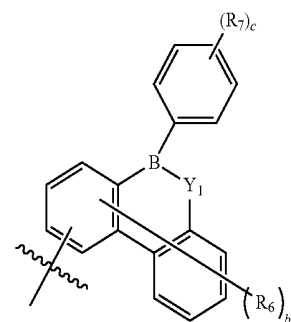

Formula 2-1

-continued

Formula 2-2

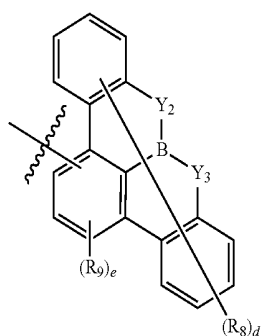

Formula 3-1

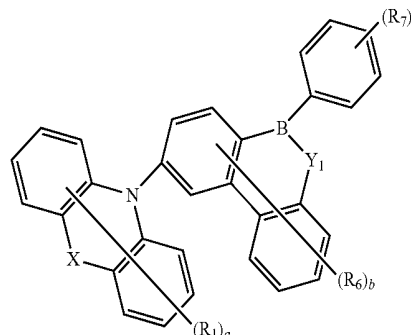

wherein in Formula 1,

R_1 is a hydrogen atom, a deuterium atom, a halogen atom, a substituted or unsubstituted silyl group, a substituted or unsubstituted amine group, a substituted or unsubstituted alkoxy group having 1 to 10 carbon atoms, a substituted or unsubstituted alkyl group having 1 to 20 carbon atoms, a substituted or unsubstituted aryl group having 6 to 20 ring-forming carbon atoms, or a substituted or unsubstituted heteroaryl group having 3 to 20 ring-forming carbon atoms,

a is an integer of 0 to 8,

X is CR_2R_3 or SiR_4R_5 ,

R_2 to R_5 are each independently a hydrogen atom, a deuterium atom, a halogen atom, a substituted or unsubstituted alkyl group having 1 to 20 carbon atoms, a substituted or unsubstituted aryl group having 6 to 20 ring-forming carbon atoms, or a substituted or unsubstituted heteroaryl group having 3 to 20 ring-forming carbon atoms, or are bonded to one or more adjacent groups to form a ring,

wherein in Formula 2-1 and in Formula 2-2,

Y_1 to Y_3 are each independently O or S,

R_6 to R_9 are each independently a hydrogen atom, a deuterium atom, a halogen atom, a substituted or unsubstituted alkoxy group having 1 to 10 carbon atoms, a substituted or unsubstituted sulfide group having 1 to 10 carbon atoms, a substituted or unsubstituted amine group, a substituted or unsubstituted silyl group, a substituted or unsubstituted alkyl group having 1 to 20 carbon atoms, a substituted or unsubstituted aryl group having 6 to 20 ring-forming carbon atoms, or a substituted or unsubstituted heteroaryl group having 3 to 20 ring-forming carbon atoms,

b is an integer of 0 to 7,

c is an integer of 0 to 5,

d is an integer of 0 to 8, and

e is an integer of 0 to 2.

14. The organic electroluminescence device of claim 13, wherein the polycyclic compound represented by Formula A is represented by Formula 3-1 or Formula 3-2:

Formula 3-2

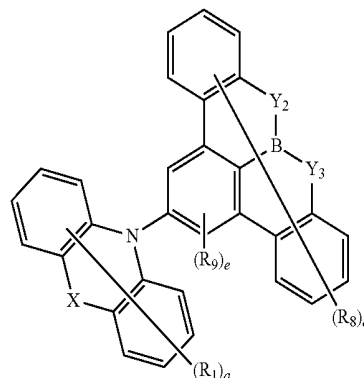

wherein in Formula 3-1 and Formula 3-2,

R_1 , X , Y_1 to Y_3 , R_6 to R_9 , and a to e are the same as respectively defined in connection with Formula 1, Formula 2-1, and Formula 2-2.

15. The organic electroluminescence device of claim 13, wherein the polycyclic compound comprises at least one of compounds represented in Compound Group 1:

Compound Group 1

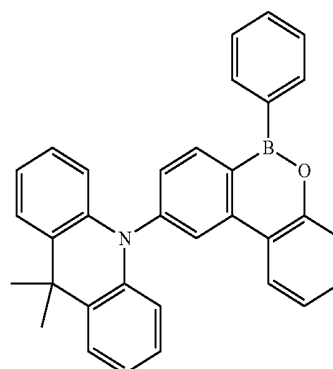

1

-continued

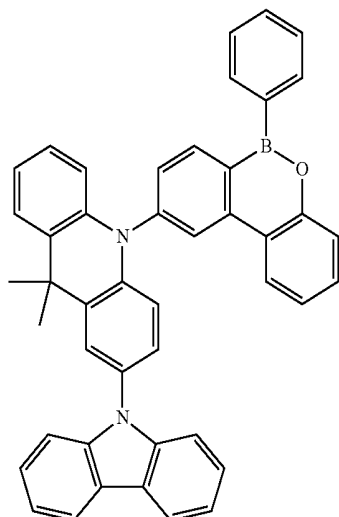
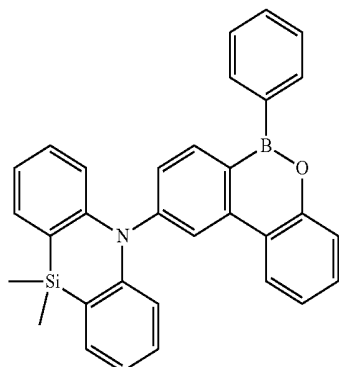
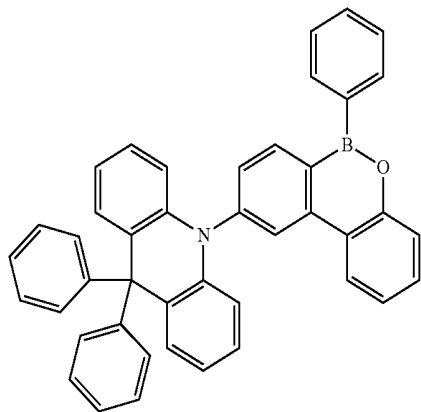

-continued

5

2

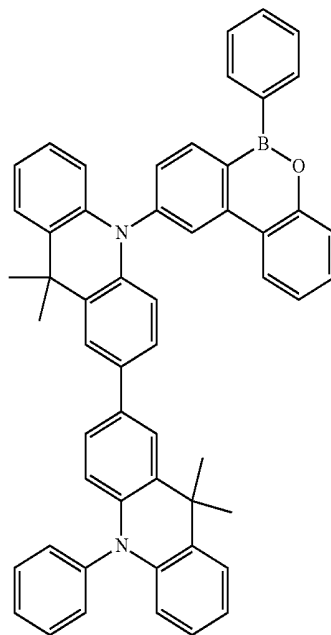

3

6

4

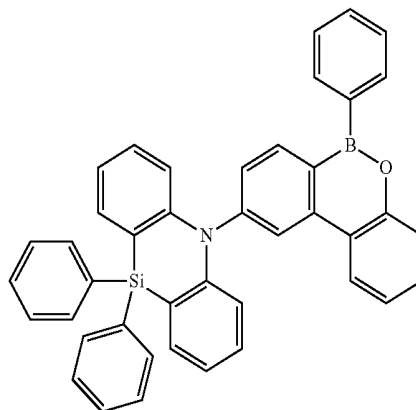

7

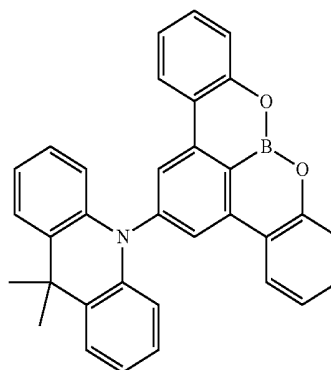

-continued

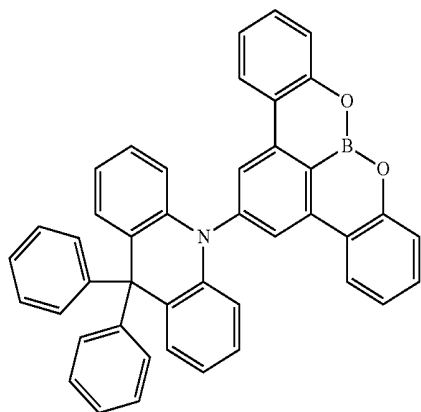

8

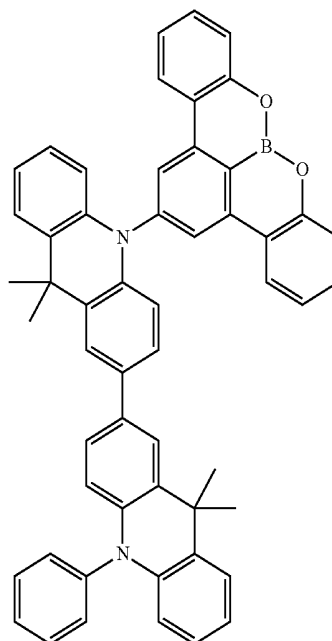

9

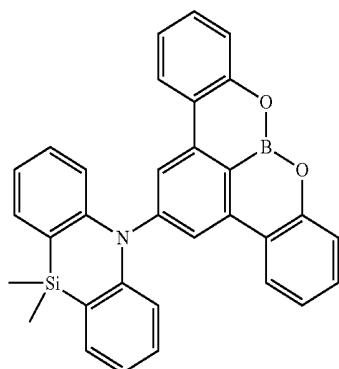

11

12

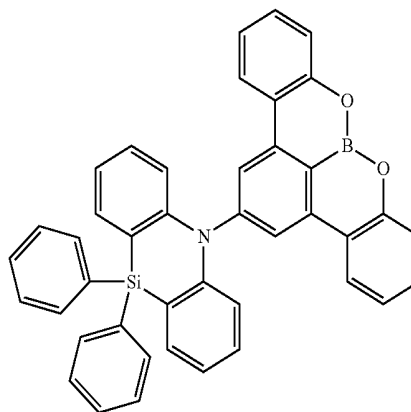

10

13

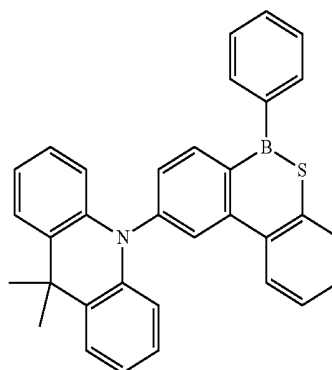
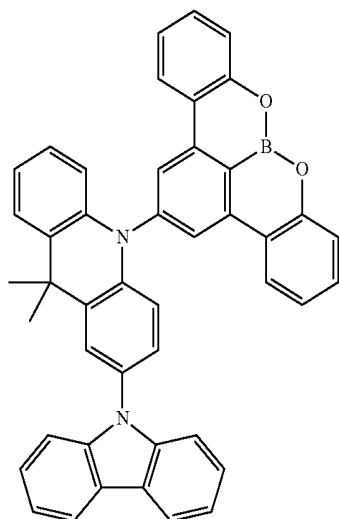

-continued

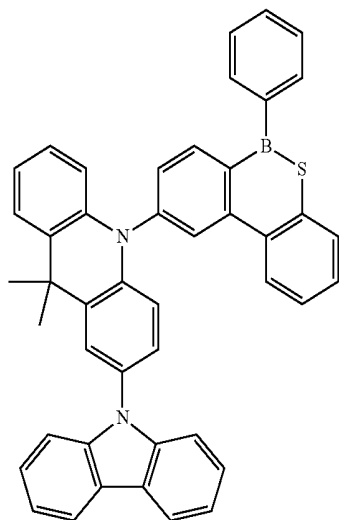
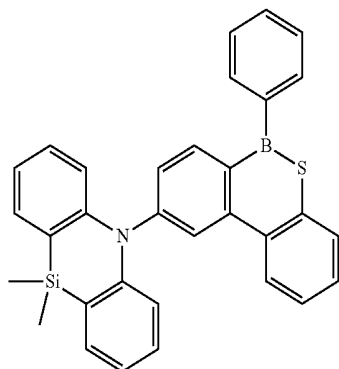
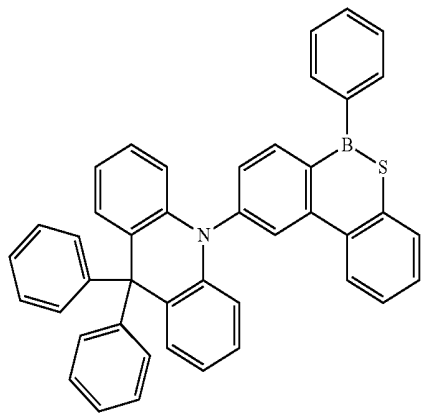

-continued

17

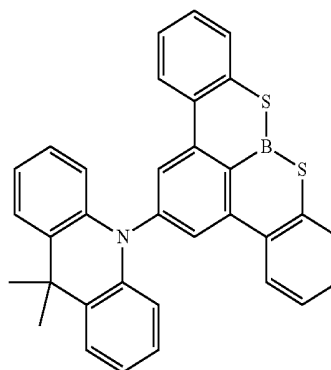
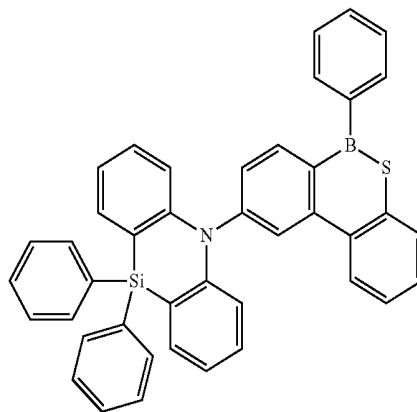
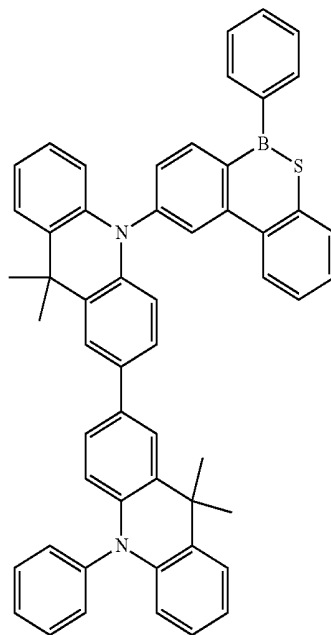

-continued

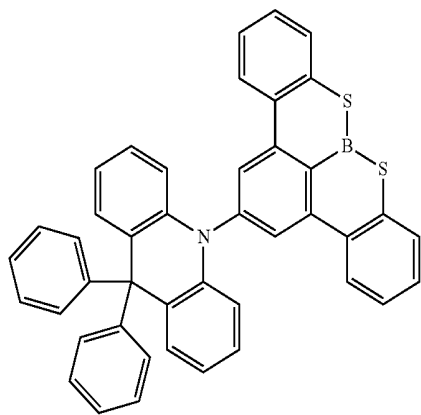

20

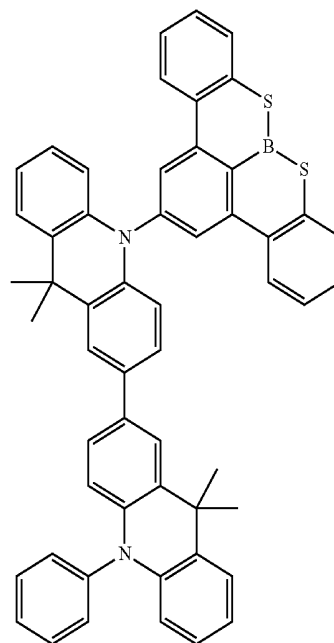

21

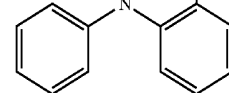

23

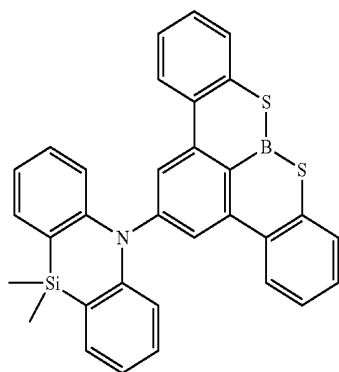

24

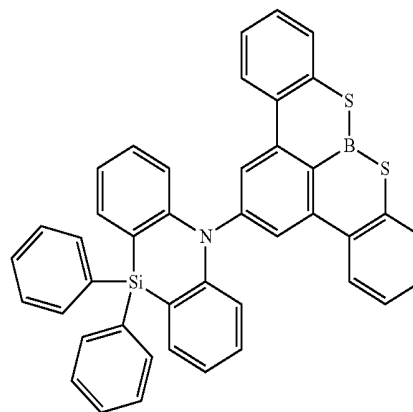

22

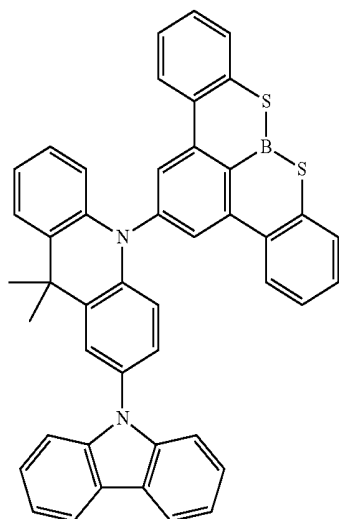

25

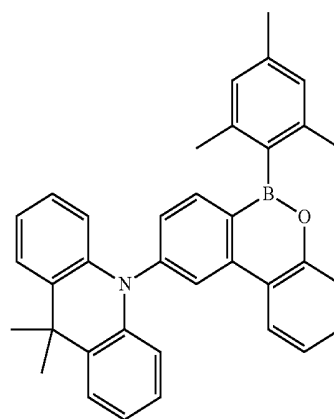

-continued

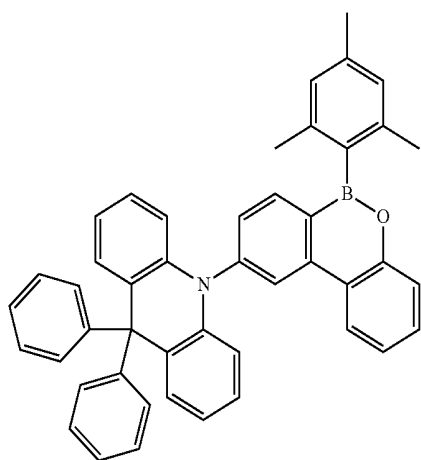

26

-continued

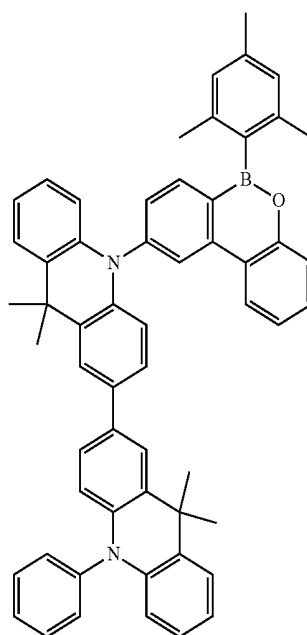

27

29

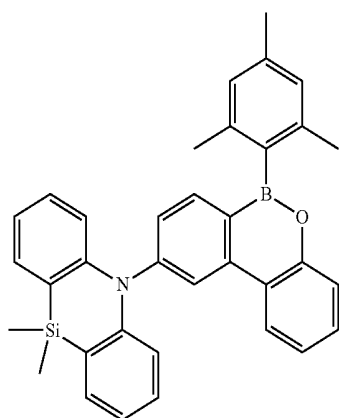

28

30

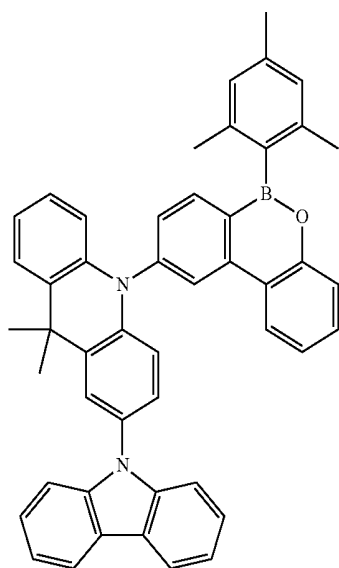

31

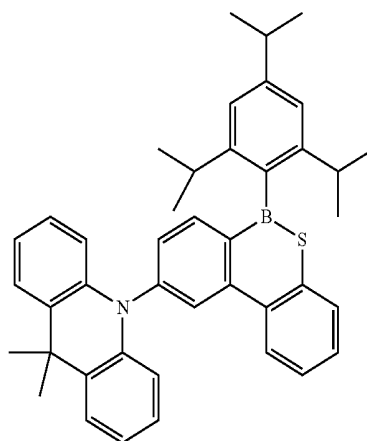
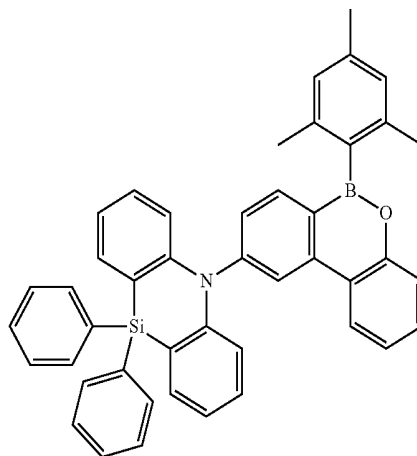

-continued

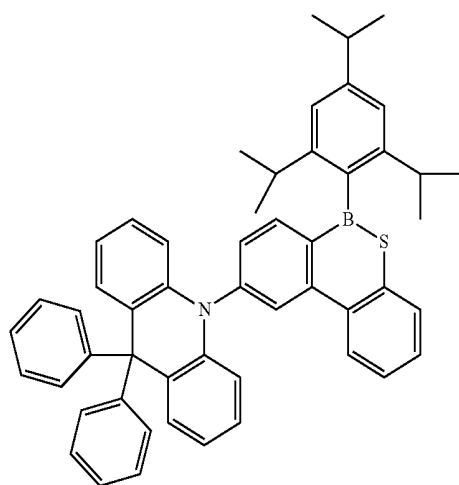

32

-continued

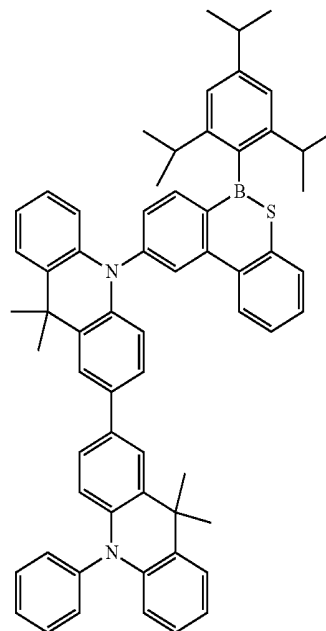

35

33

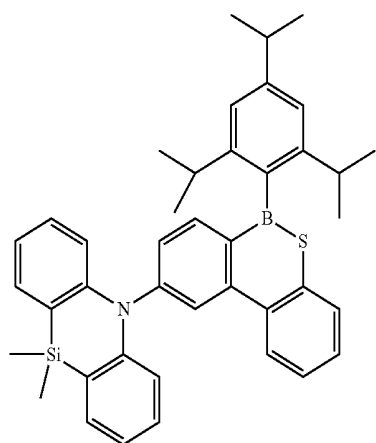

34

36

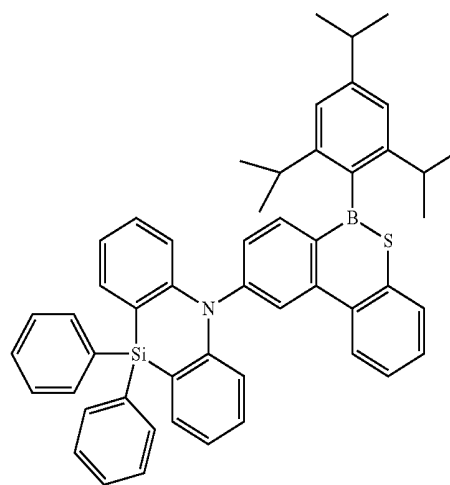

37

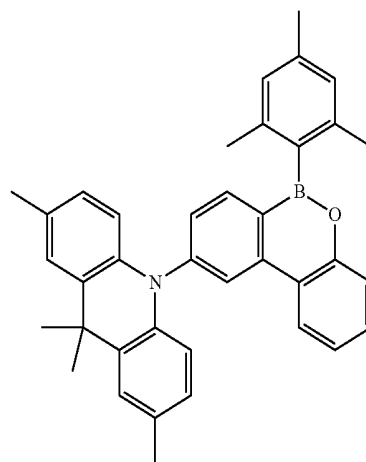
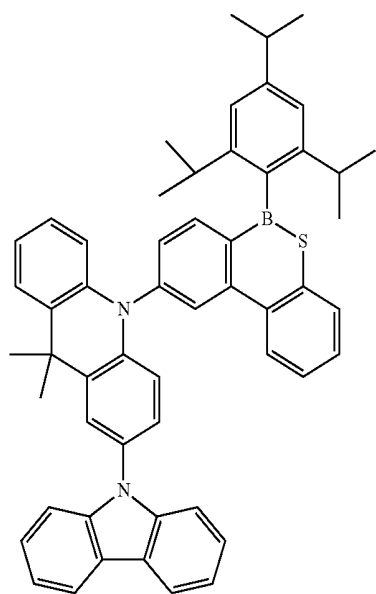

-continued

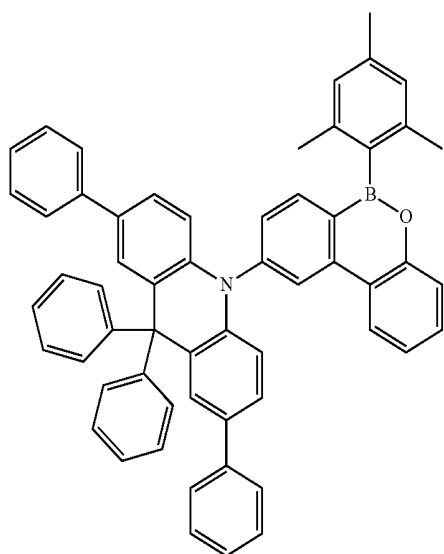

-continued

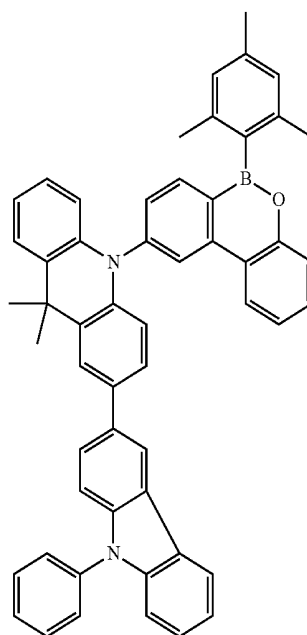

39

41

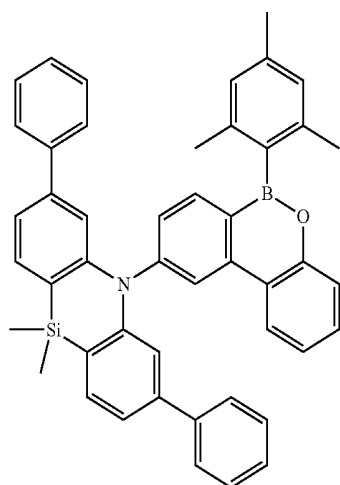

40

42

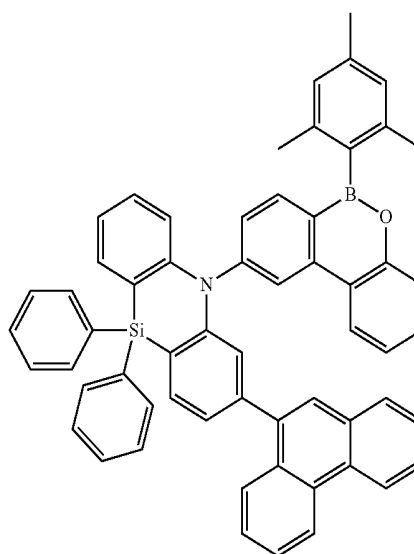

43

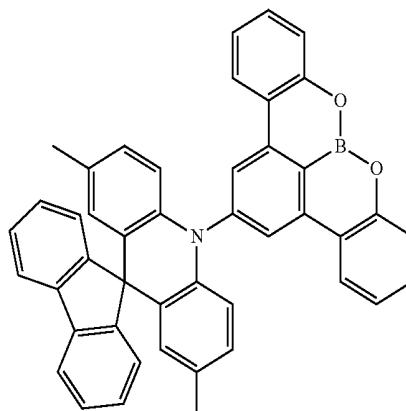
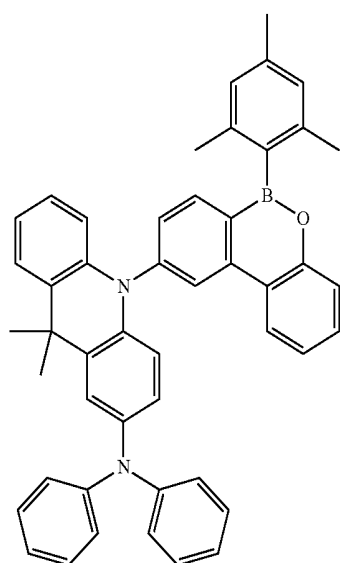

-continued

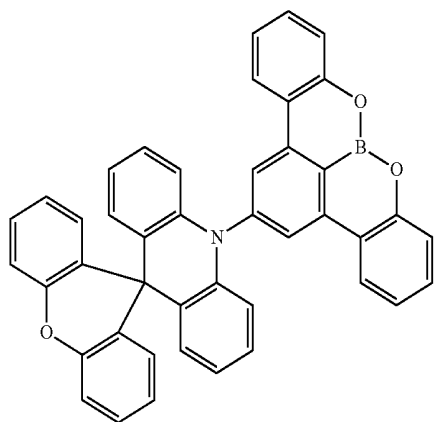

44

-continued

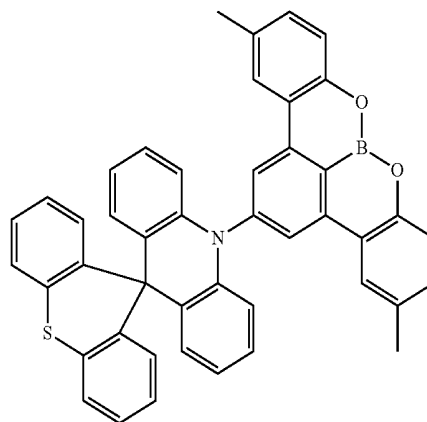

47

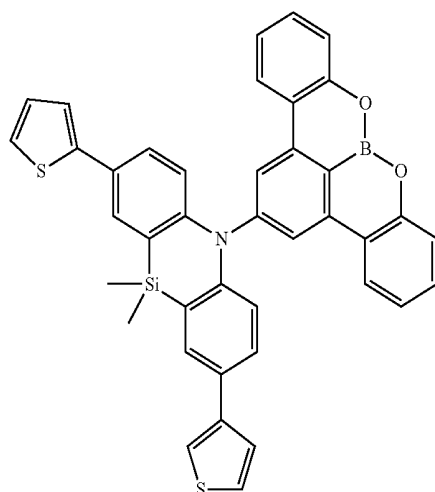

45

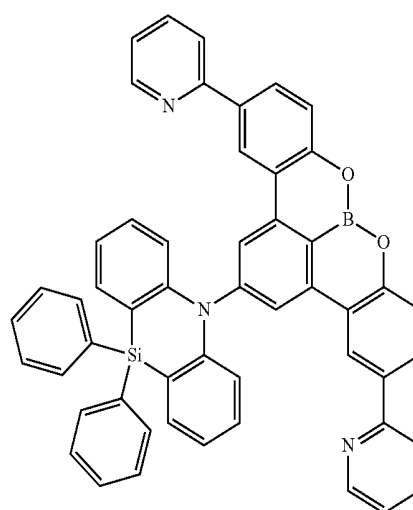

48

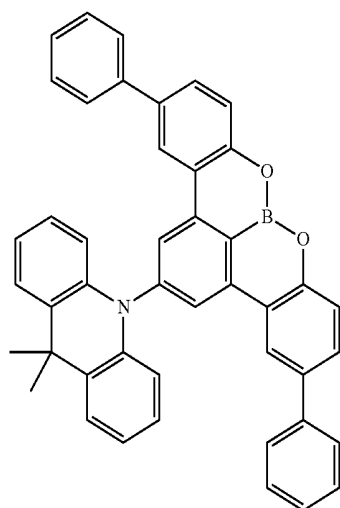

46

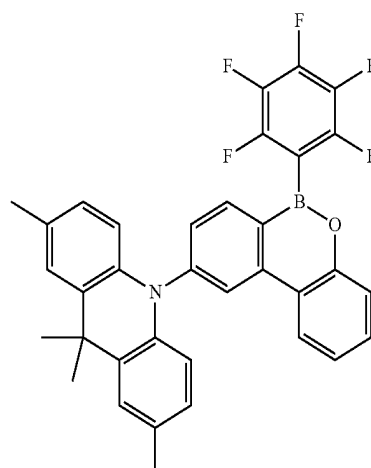

49

-continued

50

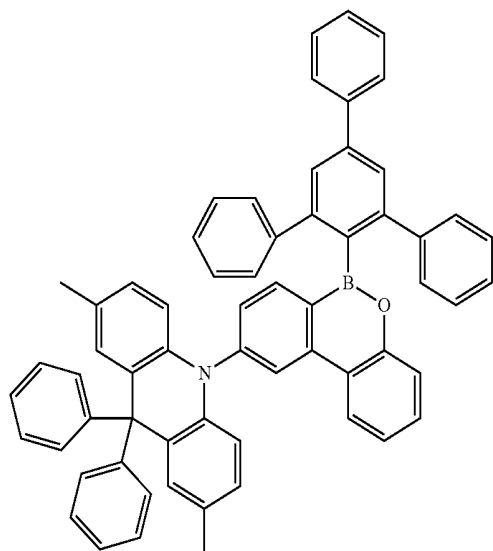

51

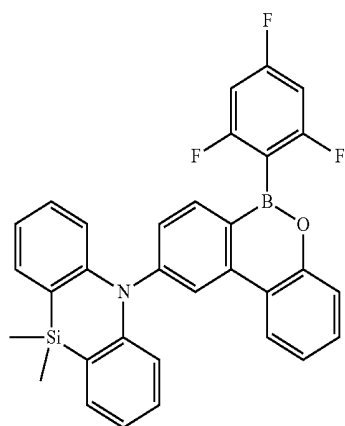

52

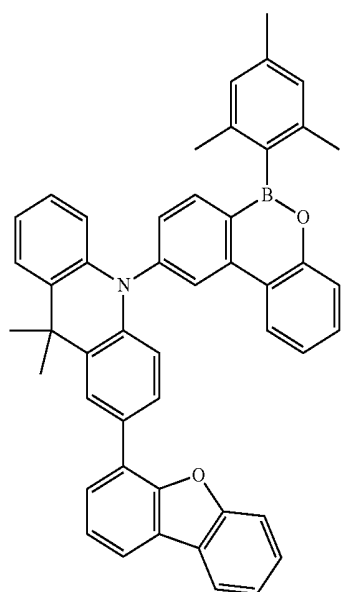

-continued

53

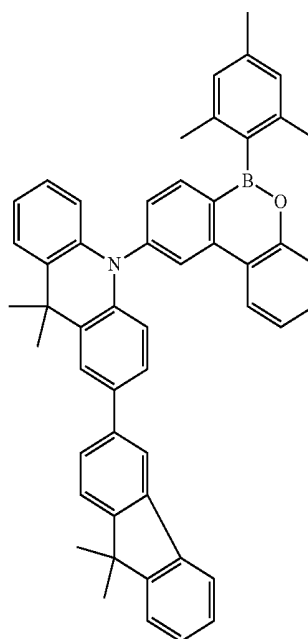

54

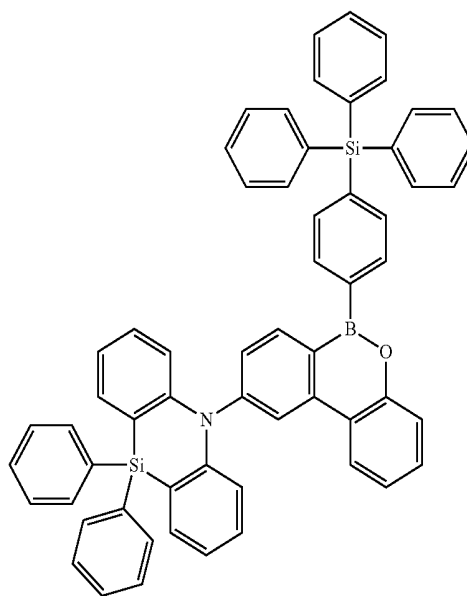

55

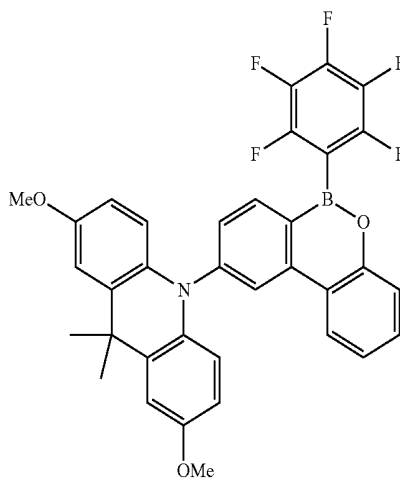

-continued

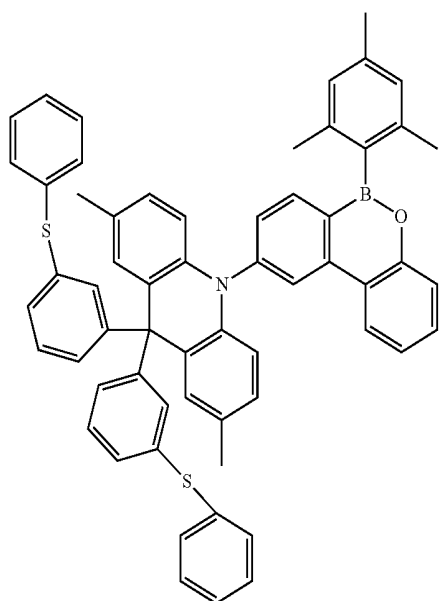

56

-continued

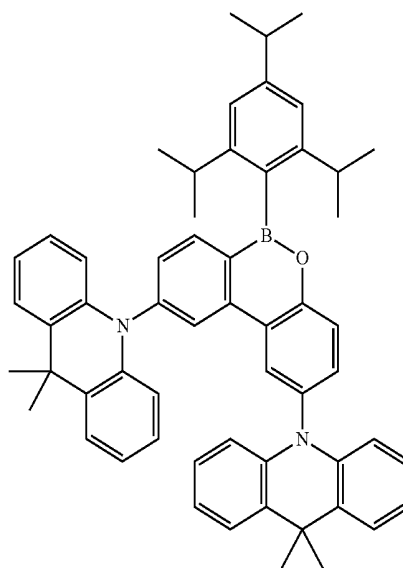

60

57

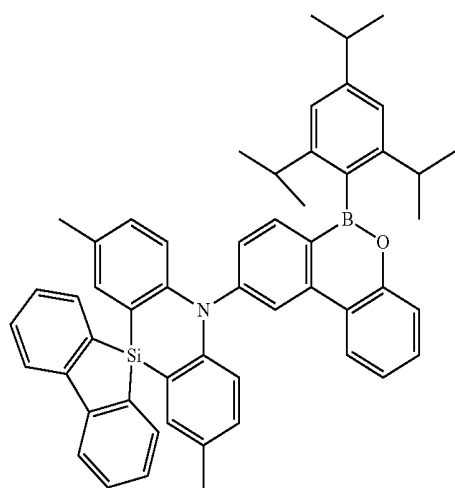

61

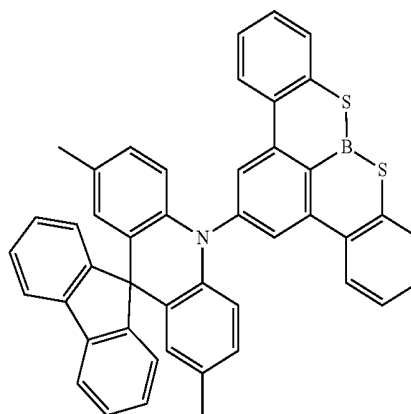

58

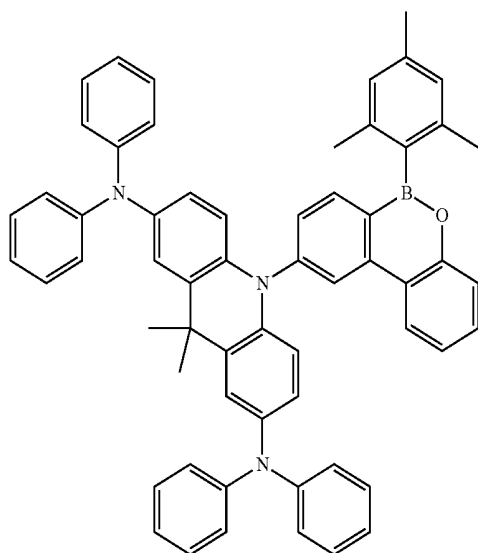

62

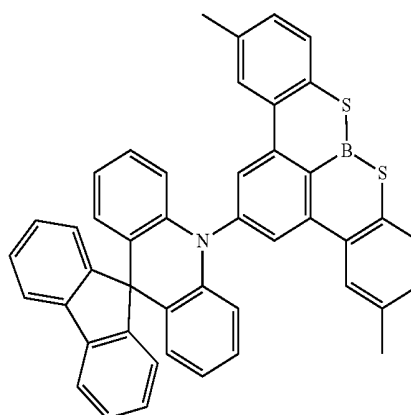

-continued

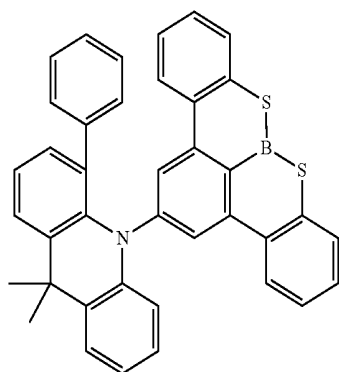

63

-continued

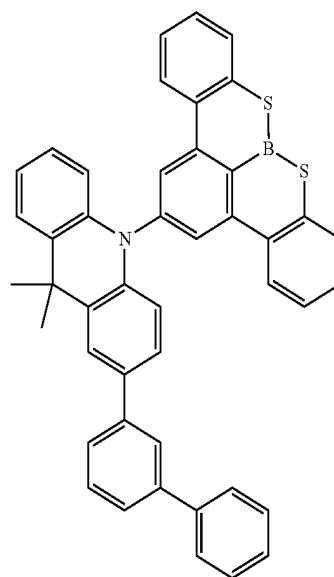

66

64

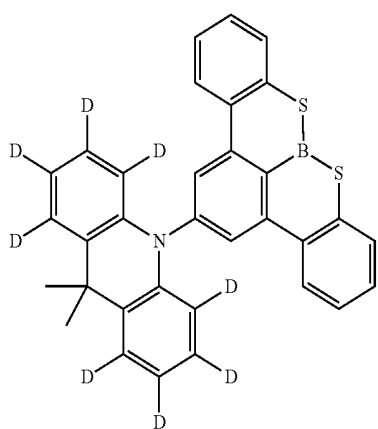

67

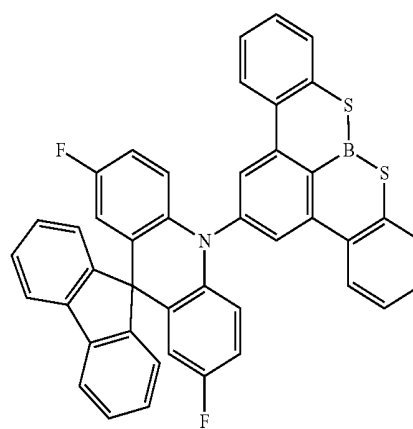

65

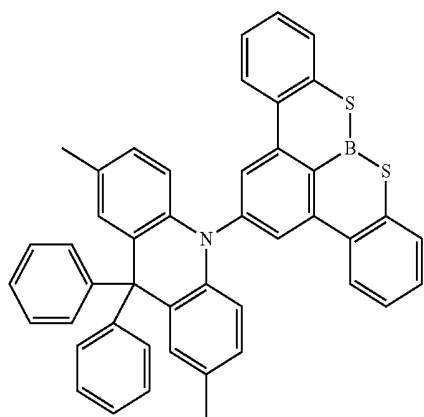

68

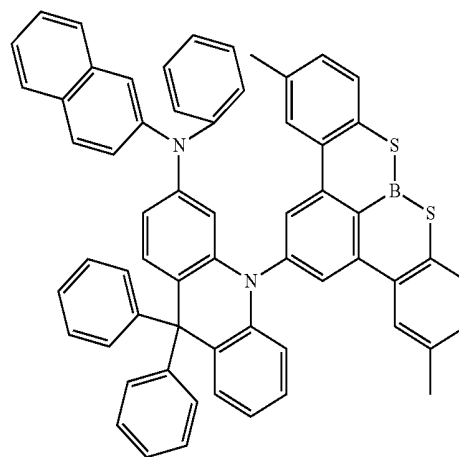

-continued

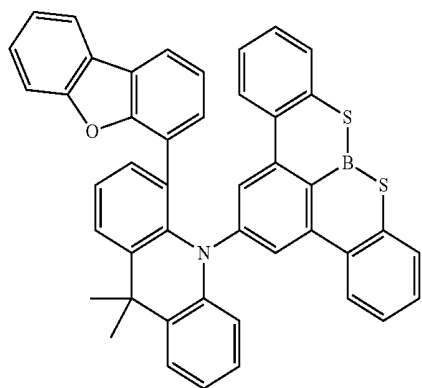

69

-continued

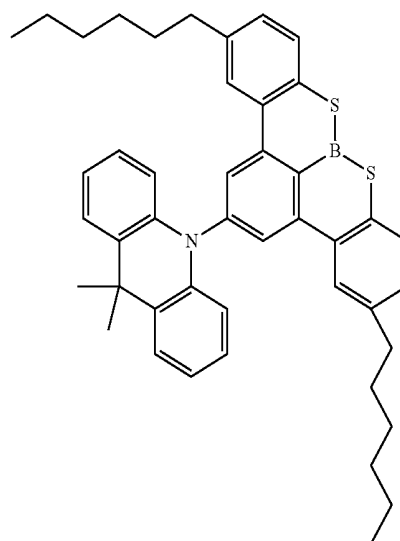

72

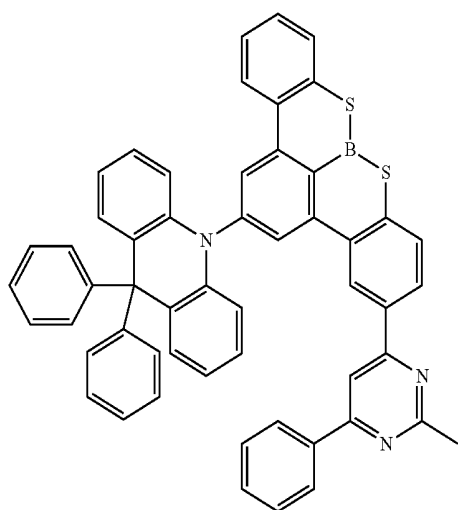

70

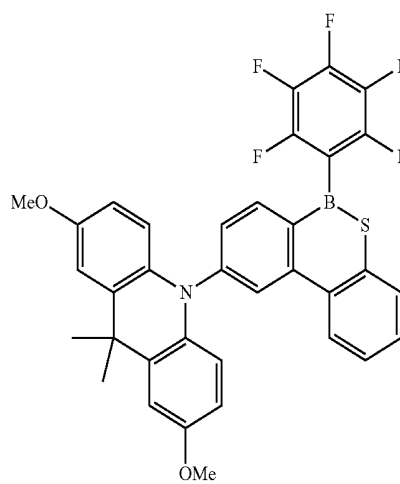

73

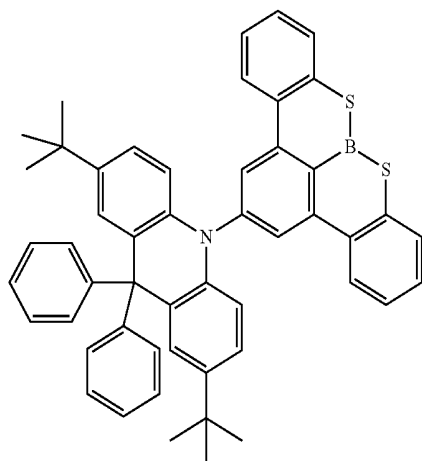

71

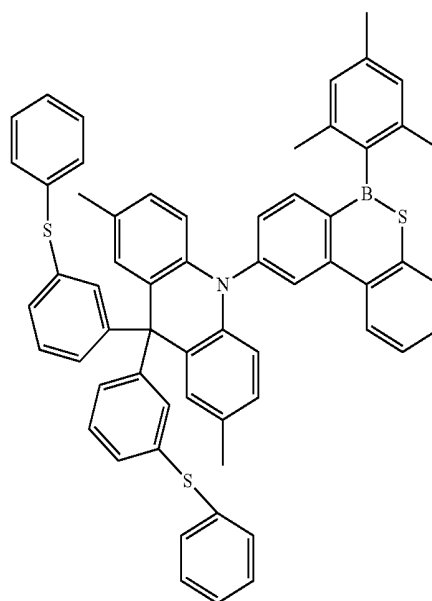

74

-continued

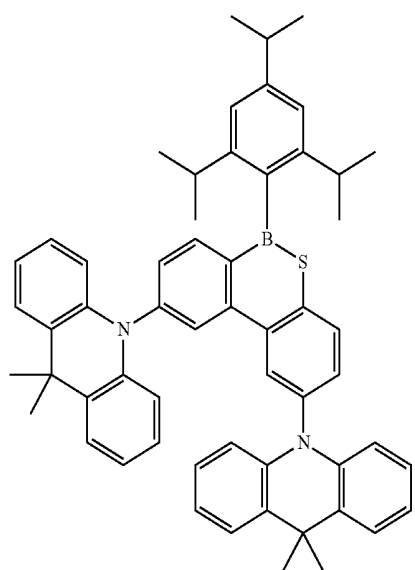
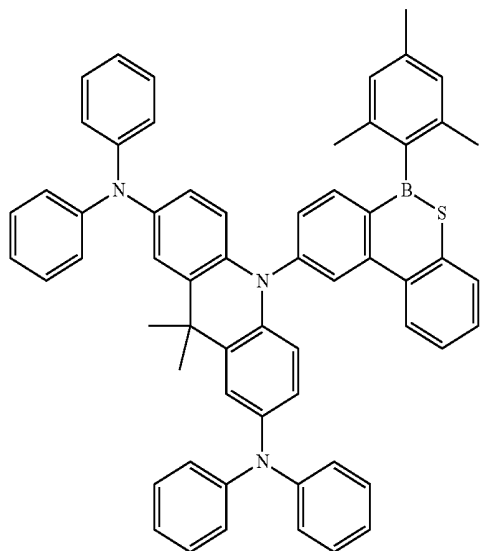
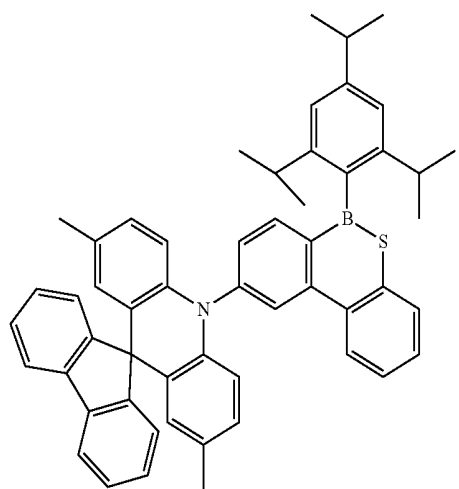

-continued

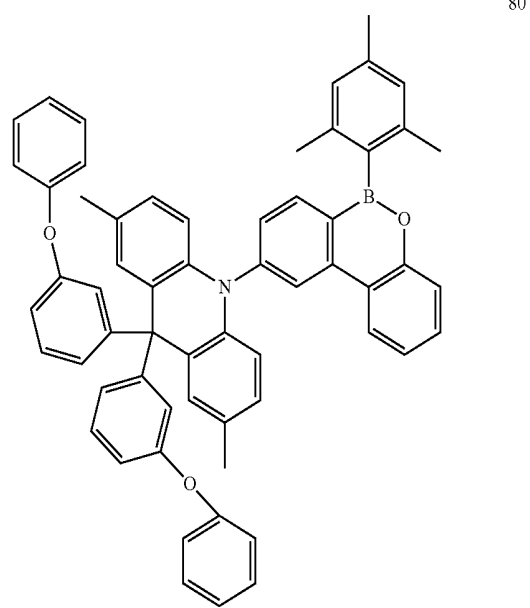
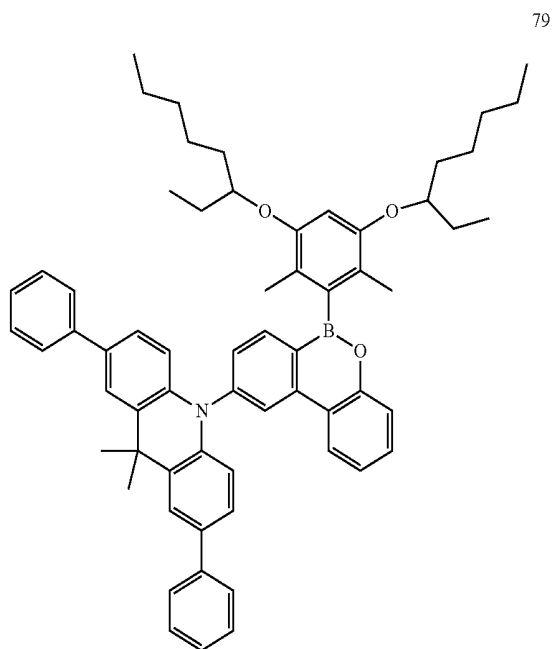

-continued

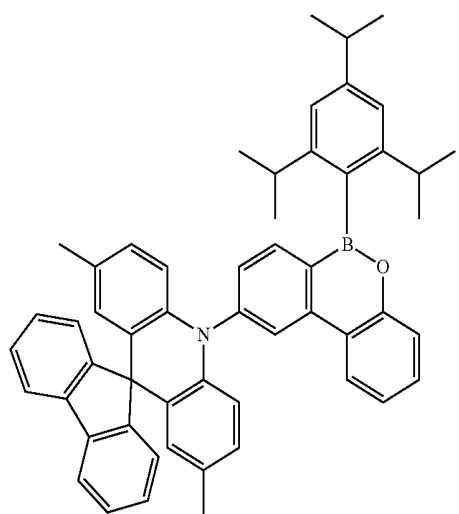

81

-continued

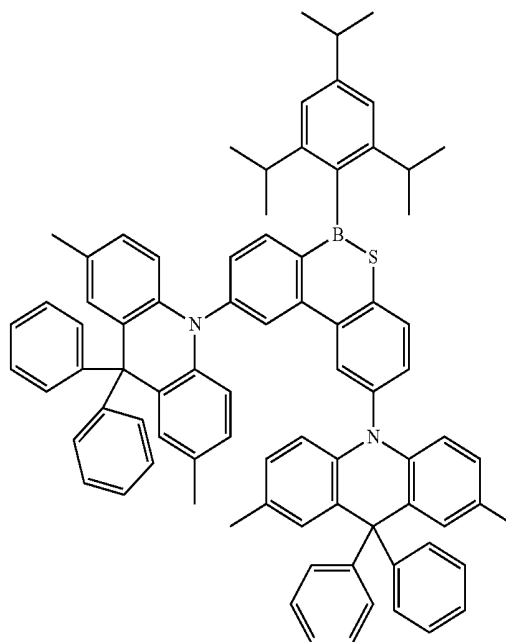

84

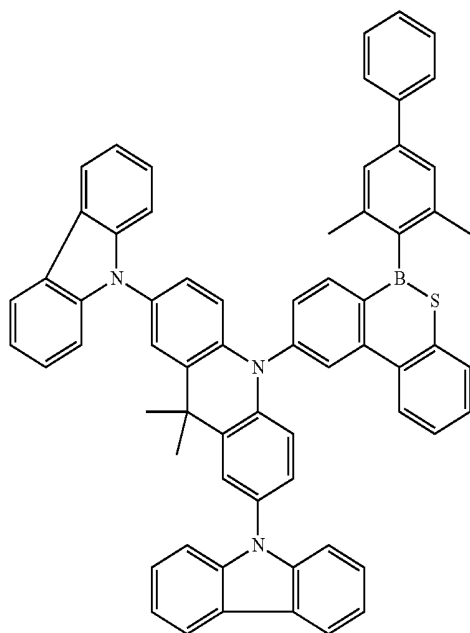

82

16. A polycyclic compound represented by Formula A:

DU-AU

Formula A

wherein in Formula A,

DU is represented by Formula 1, and AU is represented by Formula 2-1 or Formula 2-2:

Formula 1

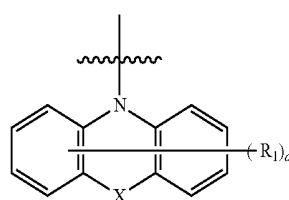

83

Formula 2-1

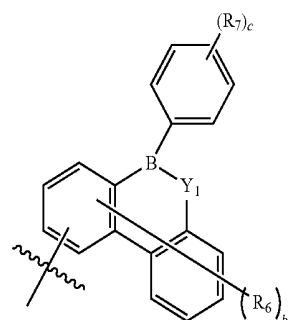

-continued

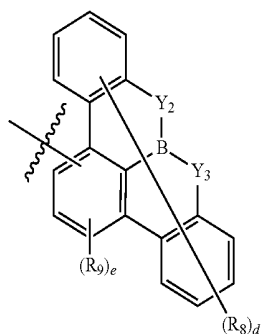

Formula 2-2

Formula 3-1

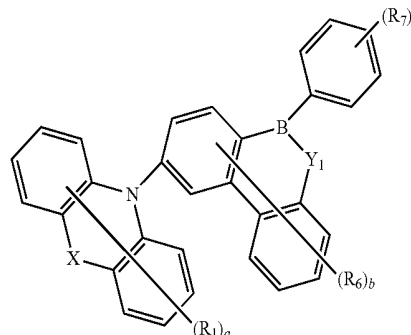

Formula 3-2

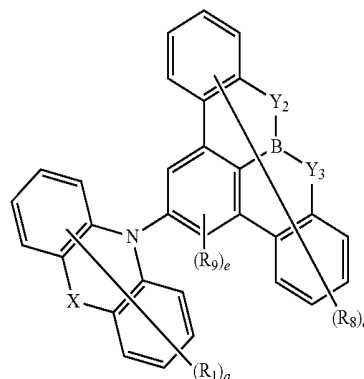

wherein in Formula 1,

R_1 is a hydrogen atom, a deuterium atom, a halogen atom, a substituted or unsubstituted silyl group, a substituted or unsubstituted amine group, a substituted or unsubstituted alkoxy group having 1 to 10 carbon atoms, a substituted or unsubstituted alkyl group having 1 to 20 carbon atoms, a substituted or unsubstituted aryl group having 6 to 20 ring-forming carbon atoms, or a substituted or unsubstituted heteroaryl group having 3 to 20 ring-forming carbon atoms,

a is an integer of 0 to 8,

X is CR_2R_3 or SiR_4R_5 ,

R_2 to R_5 are each independently a hydrogen atom, a deuterium atom, a halogen atom, a substituted or unsubstituted alkyl group having 1 to 20 carbon atoms, a substituted or unsubstituted aryl group having 6 to 20 ring-forming carbon atoms, or a substituted or unsubstituted heteroaryl group having 3 to 20 ring-forming carbon atoms, or are bonded to adjacent groups to form a ring,

wherein in Formula 2-1 and in Formula 2-2,

Y_1 to Y_3 are each independently O or S,

R_6 to R_9 are each independently a hydrogen atom, a deuterium atom, a halogen atom, a substituted or unsubstituted alkoxy group having 1 to 10 carbon atoms, a substituted or unsubstituted sulfide group having 1 to 10 carbon atoms, a substituted or unsubstituted amine group, a substituted or unsubstituted silyl group, a substituted or unsubstituted alkyl group having 1 to 20 carbon atoms, a substituted or unsubstituted aryl group having 6 to 20 ring-forming carbon atoms, or a substituted or unsubstituted heteroaryl group having 3 to 20 ring-forming carbon atoms,

b is an integer of 0 to 7,

c is an integer of 0 to 5,

d is an integer of 0 to 8, and

e is an integer of 0 to 2.

17. The polycyclic compound of claim 16, wherein the polycyclic compound represented by Formula A is represented by Formula 3-1 or Formula 3-2:

wherein in Formula 3-1 and Formula 3-2,

R_1 , X , Y_1 to Y_3 , R_6 to R_9 , and a to e are the same as respectively defined in connection with Formula 1, Formula 2-1, and Formula 2-2.

18. The polycyclic compound of claim 16, wherein DU represented by Formula 1 is represented by Formula 4:

Formula 4

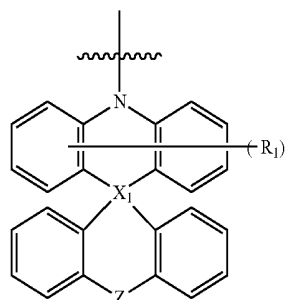

wherein in Formula 4,

X_1 is C or Si,

Z is a direct bond, O, or S, and

R_1 and a are the same as respectively defined in connection with Formula 1.

19. The polycyclic compound of claim 16, wherein AU represented by Formula 2-2 is represented by Formula 5-1 or Formula 5-2:

-continued

Formula 5-1

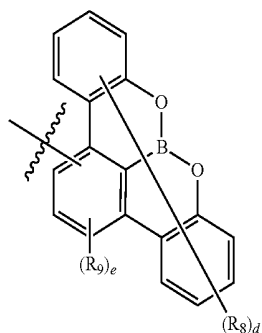

2

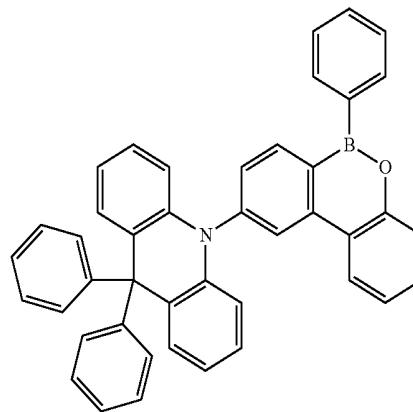

Formula 5-2

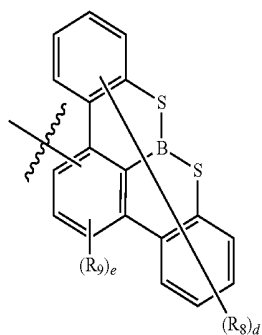

3

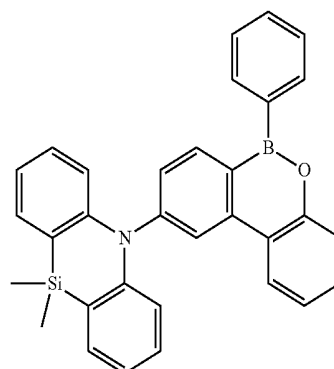

wherein in Formula 5-1 and Formula 5-2,

R_8 , R_9 , d, and e are the same as respectively defined in connection with Formula 2-2.

20. The polycyclic compound of claim 16, wherein the polycyclic compound is any one of compounds represented in Compound Group 1:

Compound Group 1

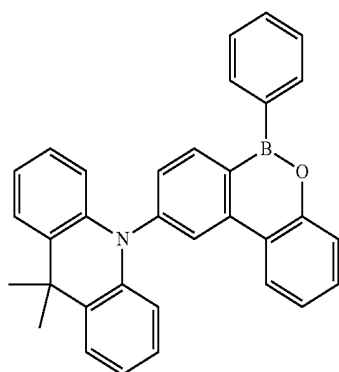

1

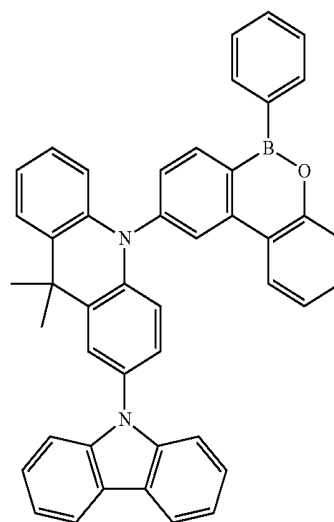

4

-continued

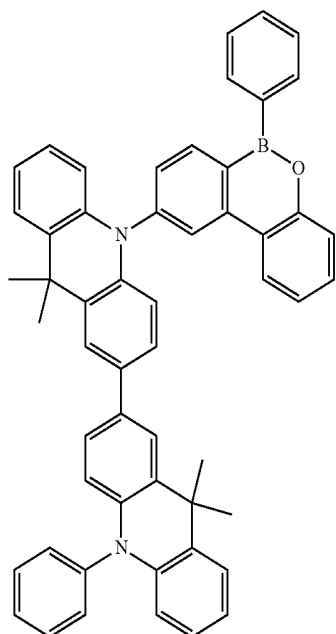

5

-continued

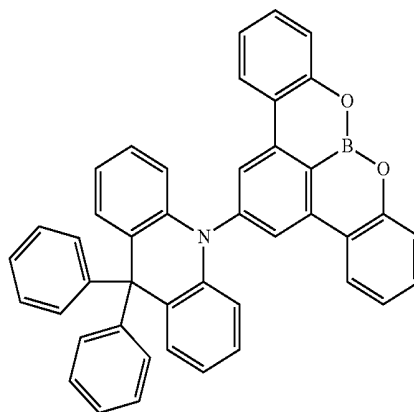

8

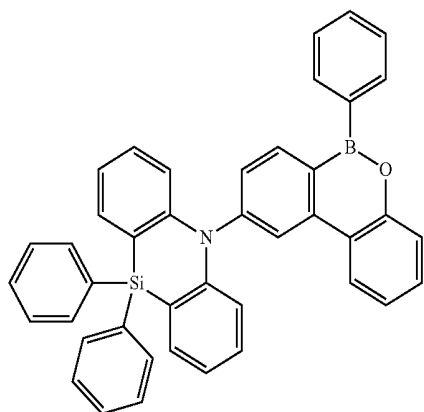

6

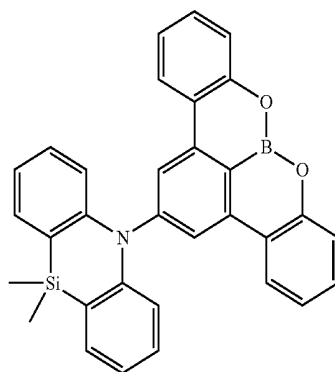

9

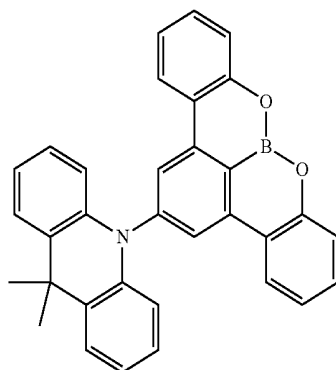

7

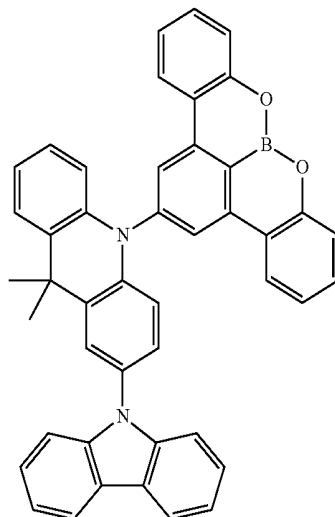

10

-continued

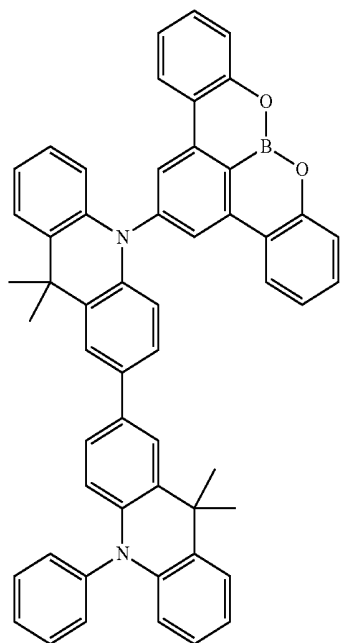

11

-continued

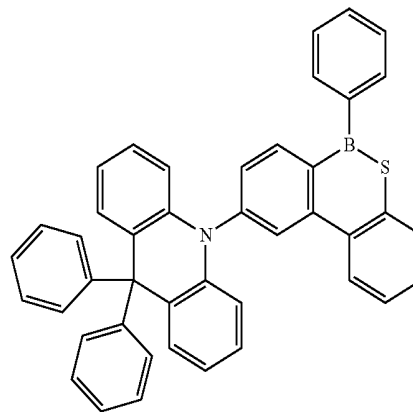

14

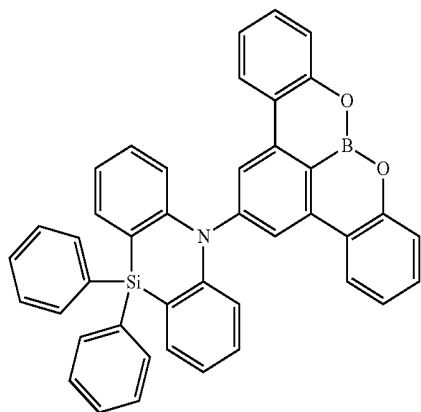

12

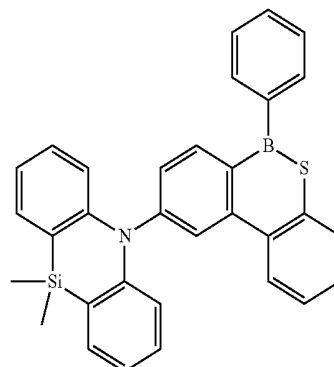

15

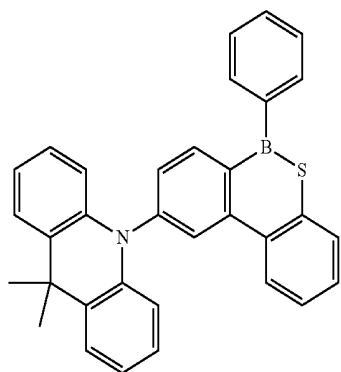

13

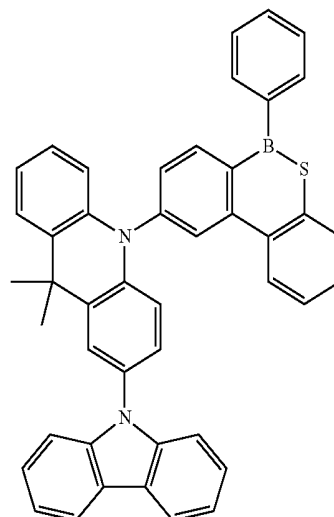

16

-continued

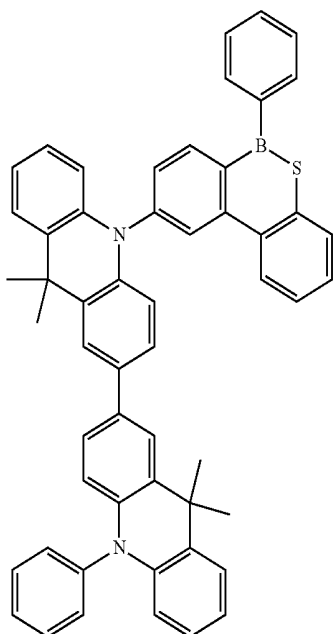

17

-continued

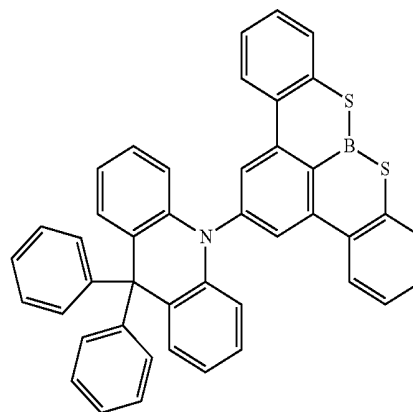

20

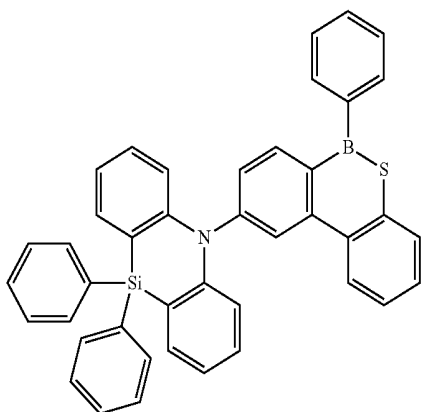

18

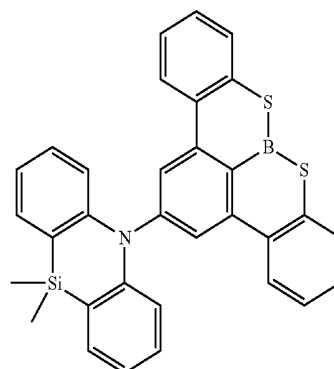

21

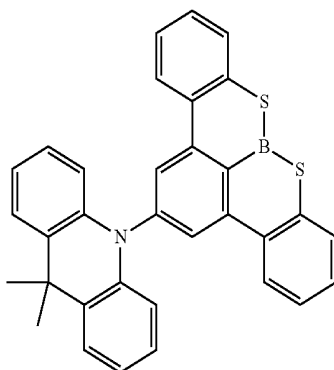

19

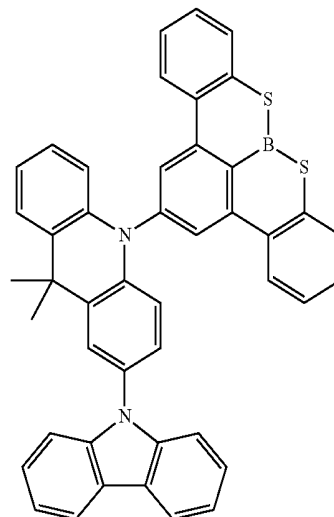

22

-continued

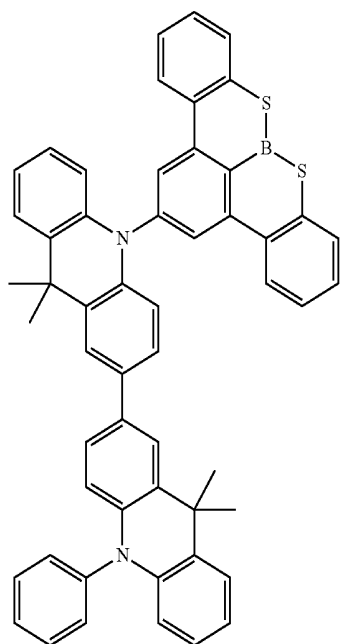

23

-continued

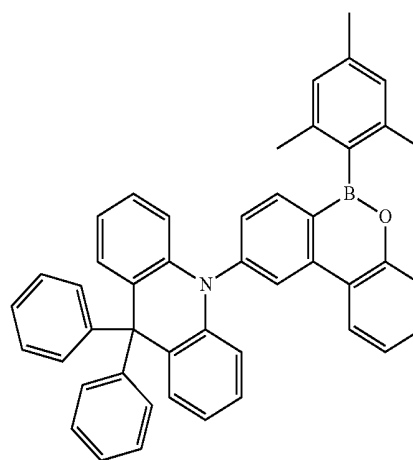

26

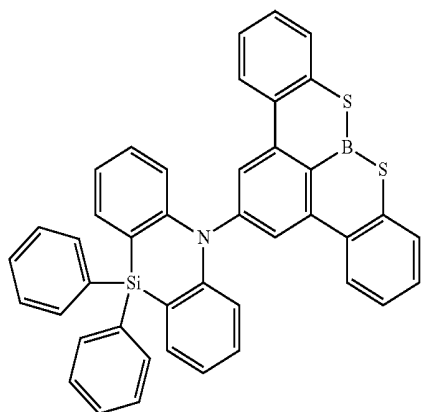

24

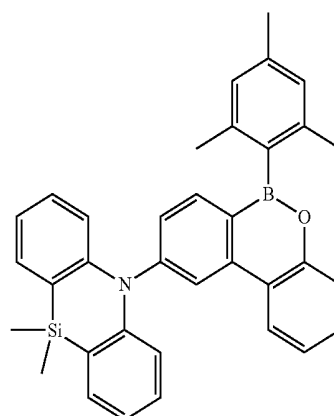

27

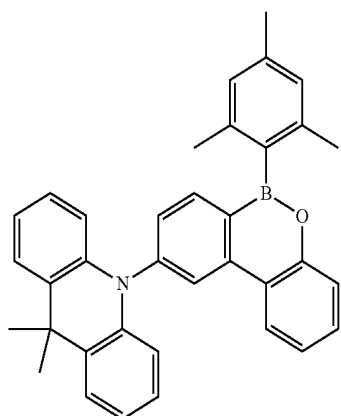

25

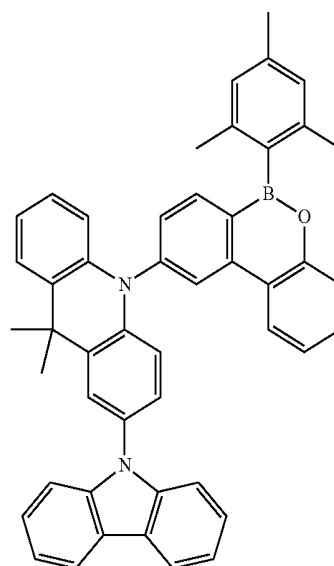

28

-continued

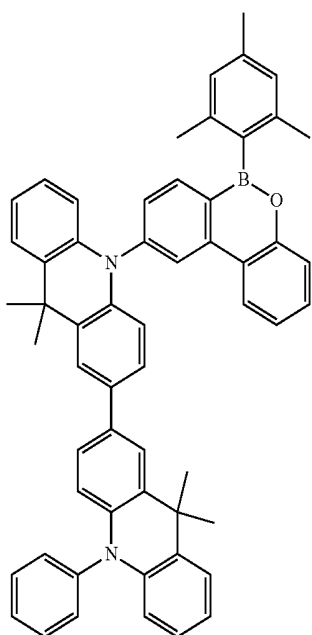

-continued

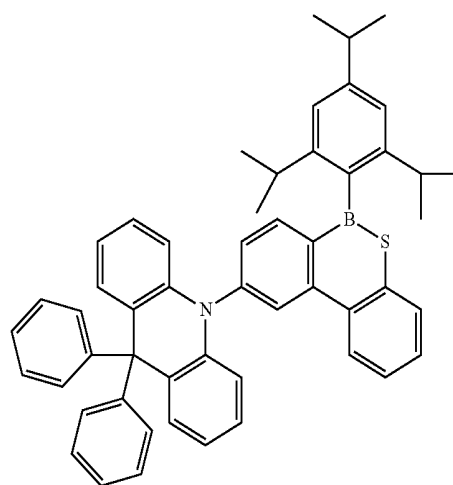

30

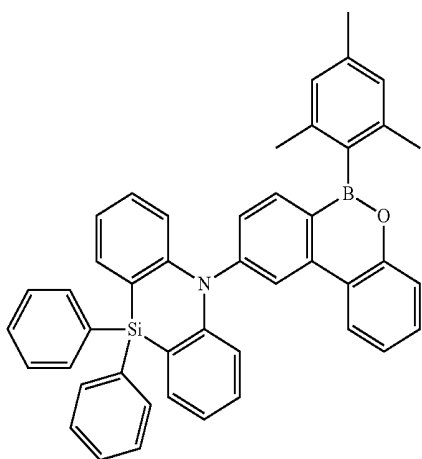

31

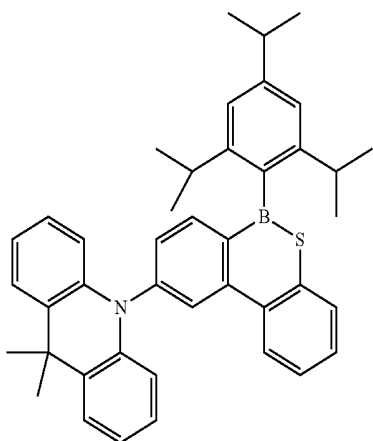

33

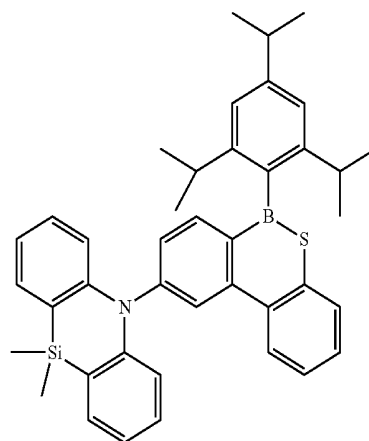

34

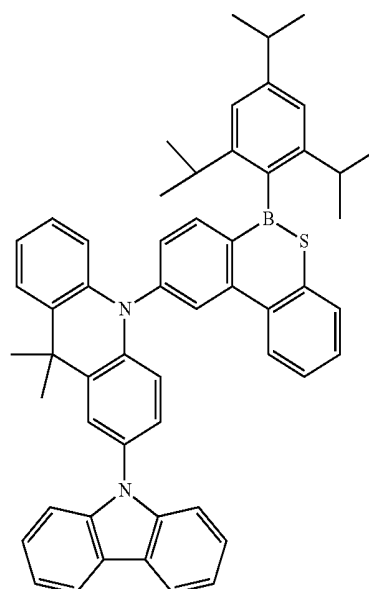

-continued

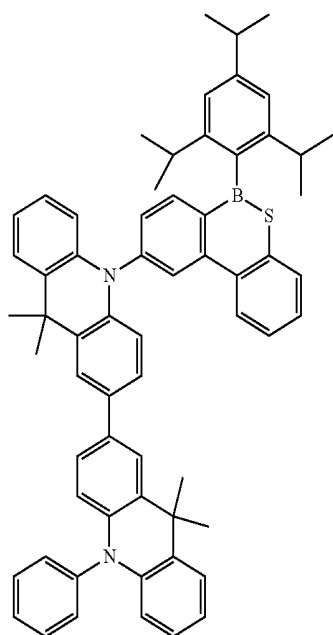

35

-continued

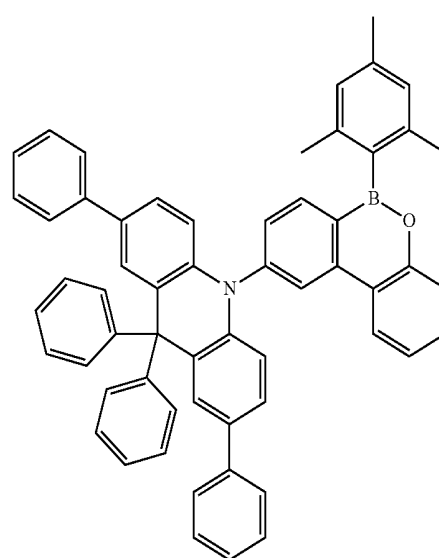

38

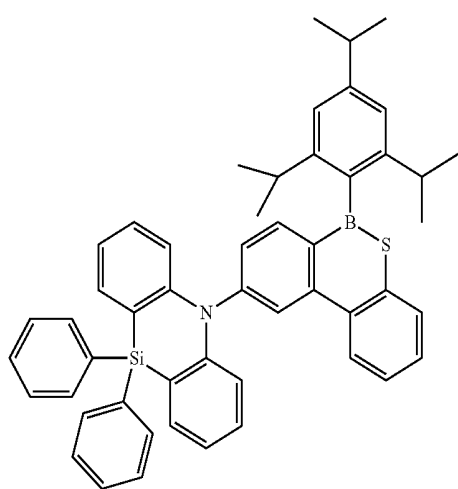

36

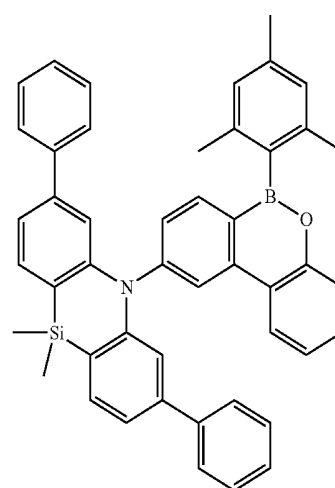

39

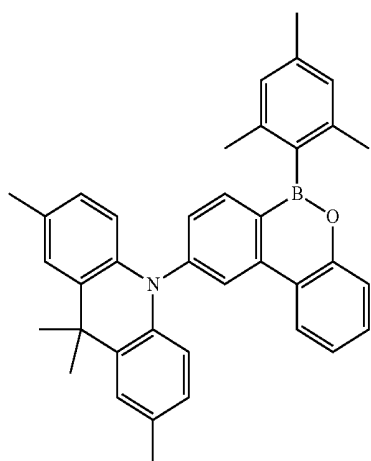

37

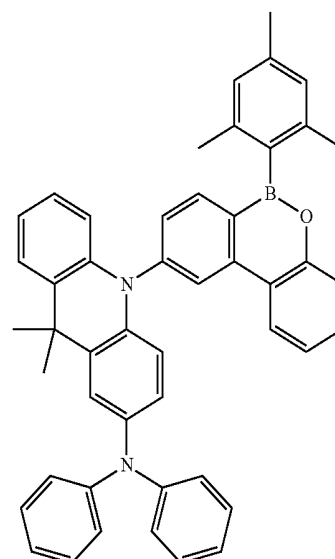

40

-continued

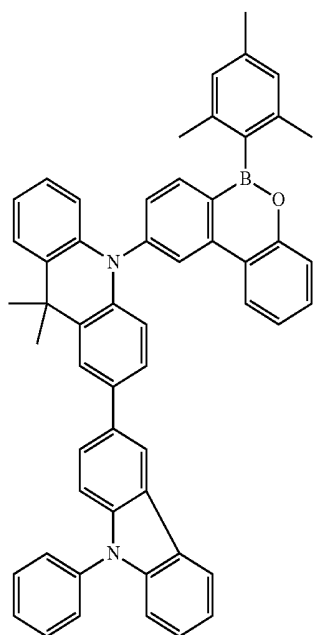

41

-continued

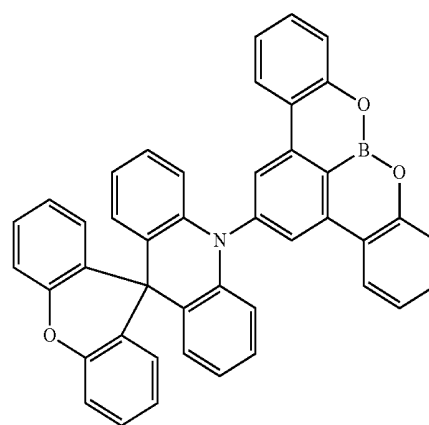

44

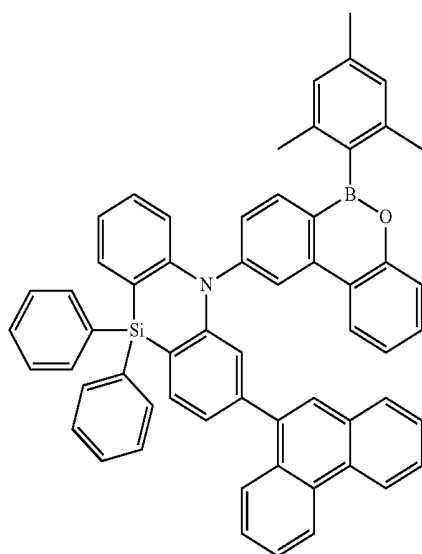

42

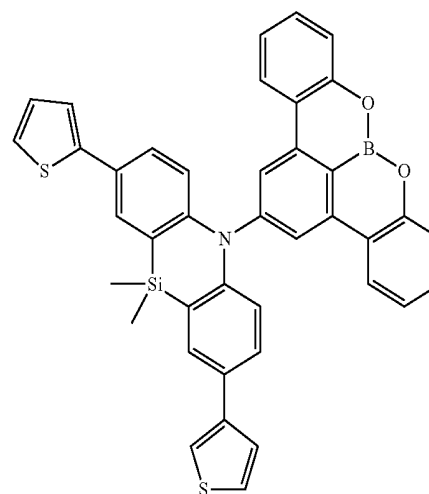

45

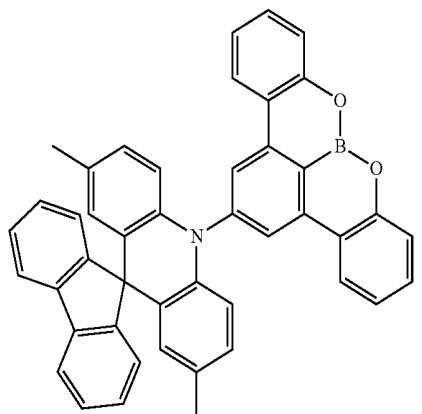

43

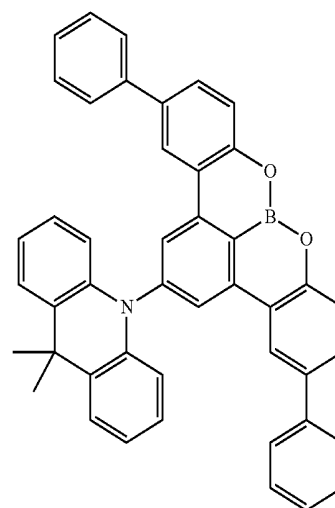

46

-continued

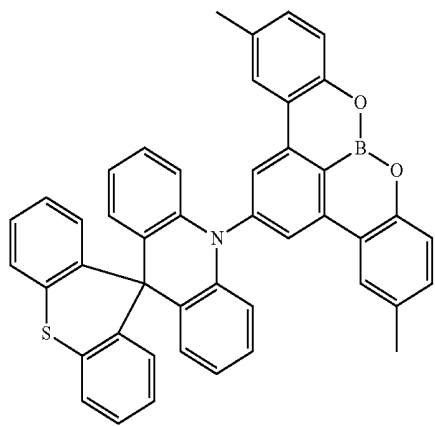

-continued

50

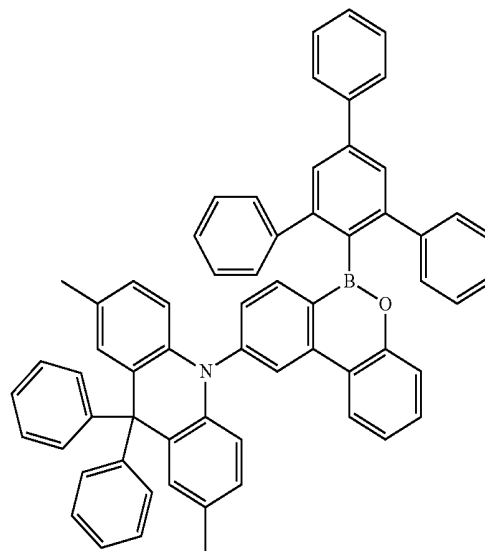

48

51

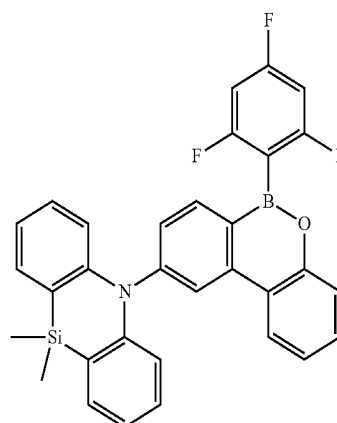
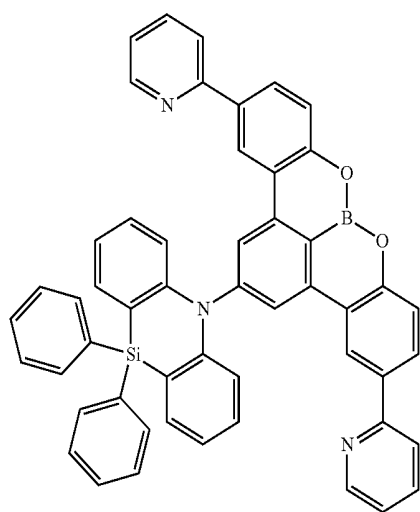

52

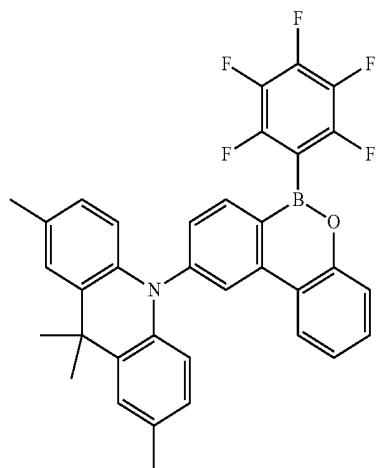

49

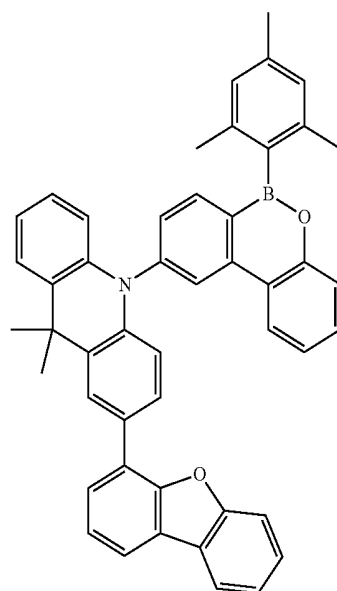

-continued

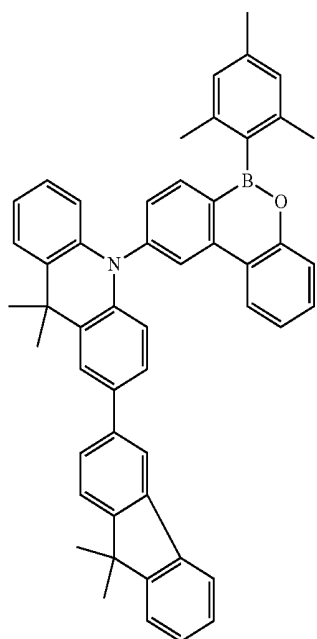

53

-continued

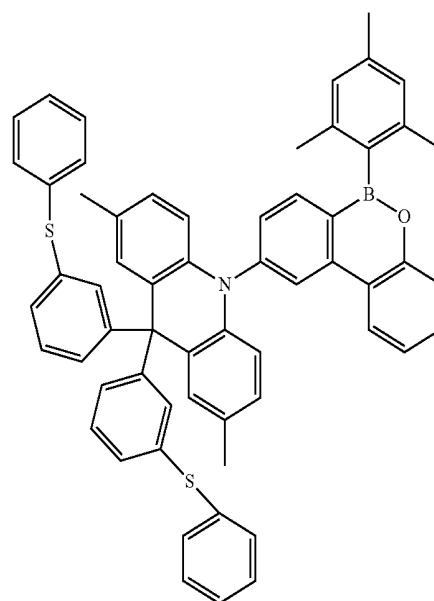

56

54

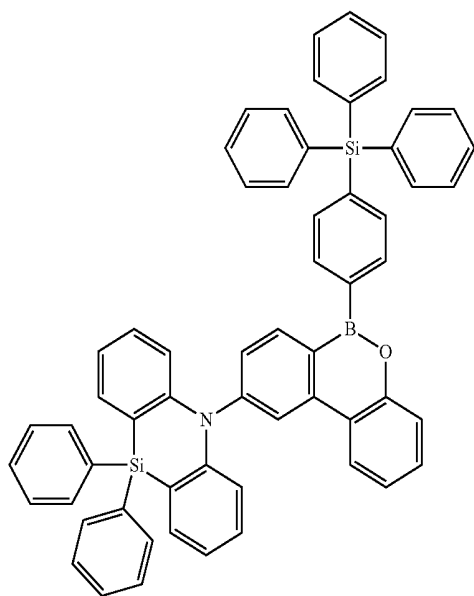

54

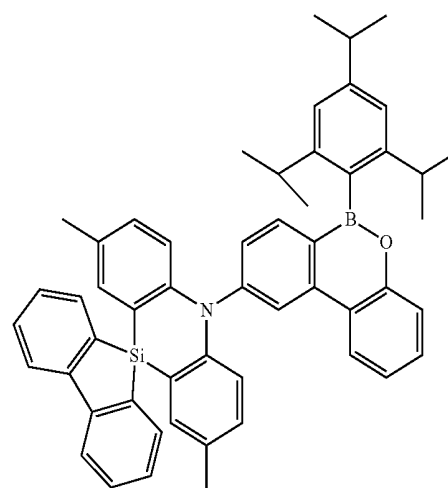

57

55

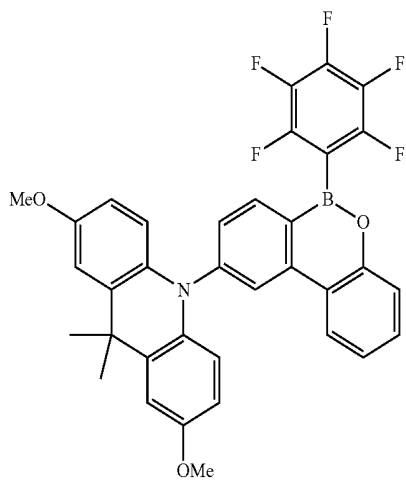

55

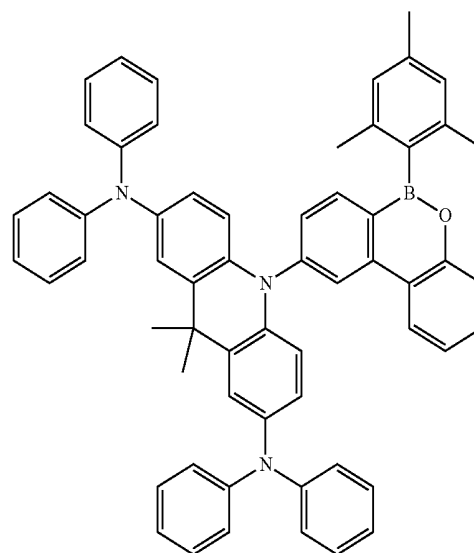

58

-continued

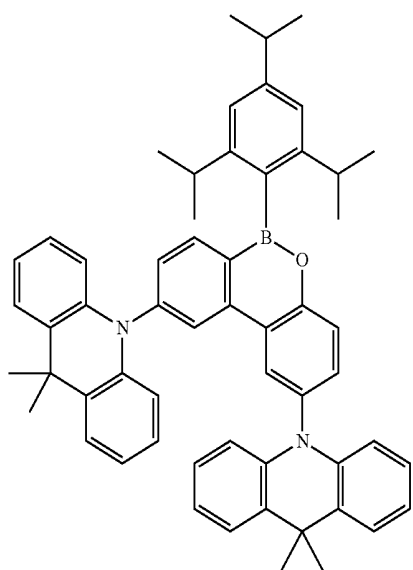

60

-continued

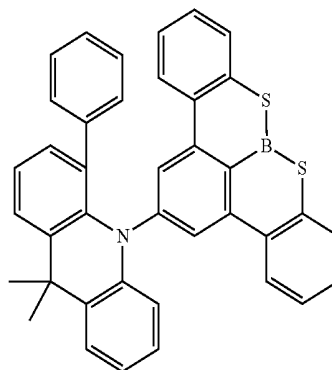

63

61

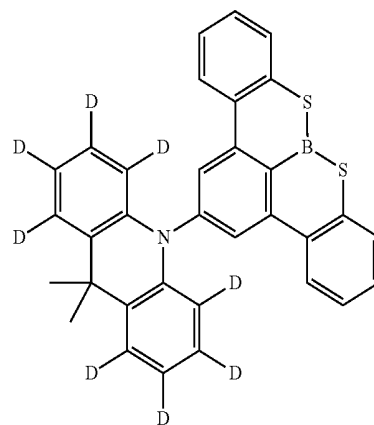
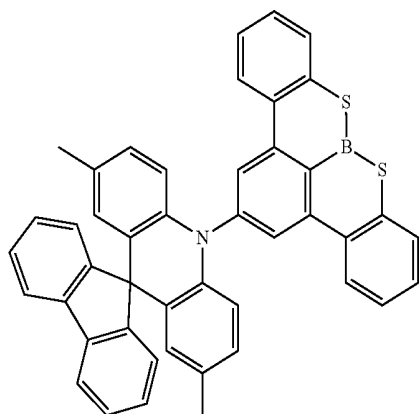

64

62

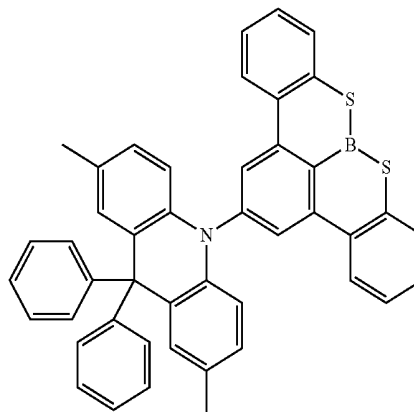
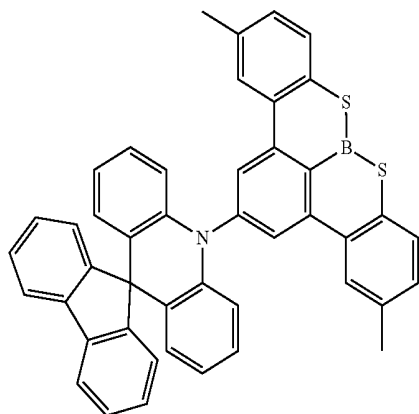

65

-continued

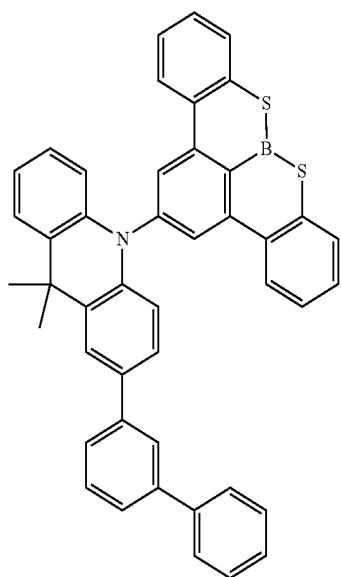

-continued

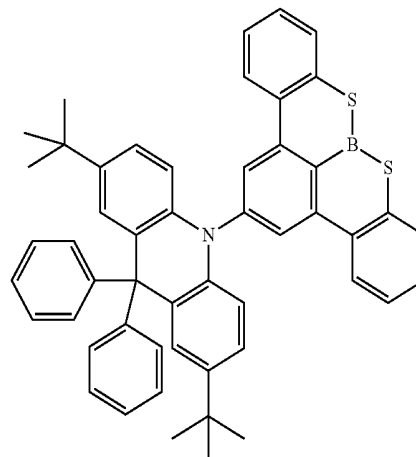
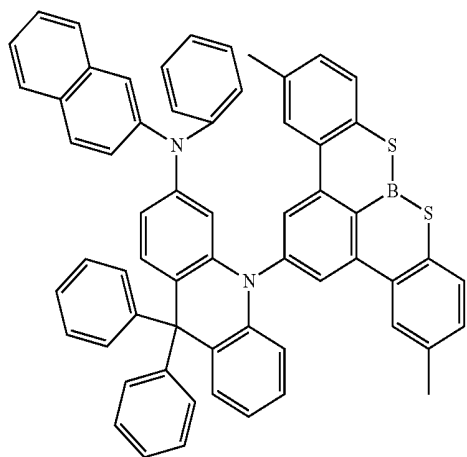
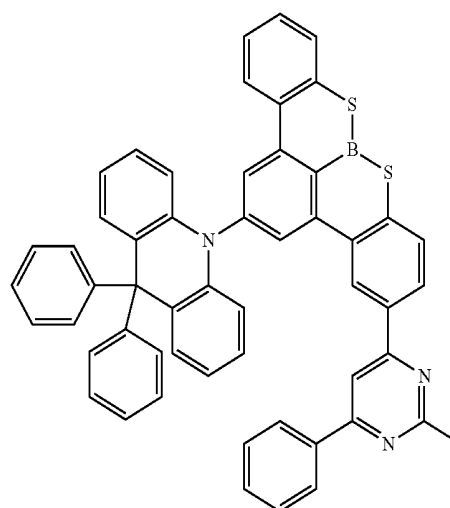
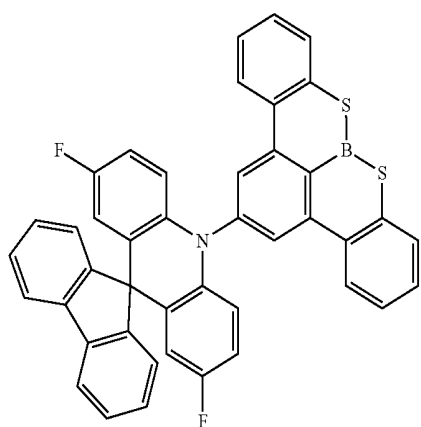
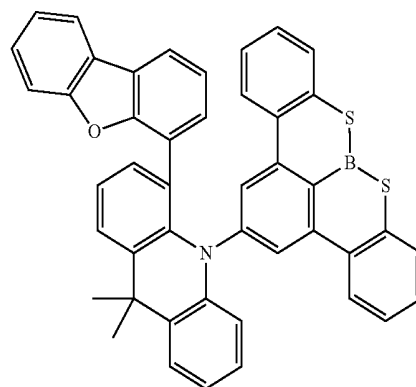

-continued

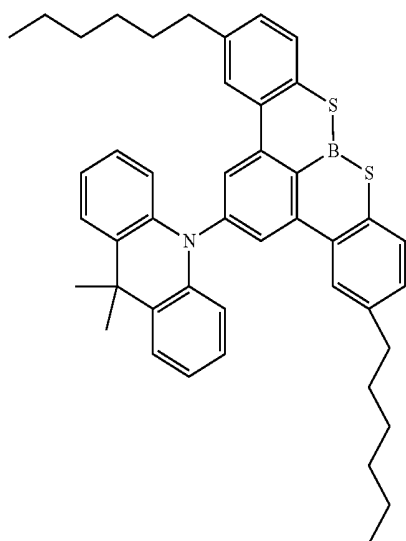

72

-continued

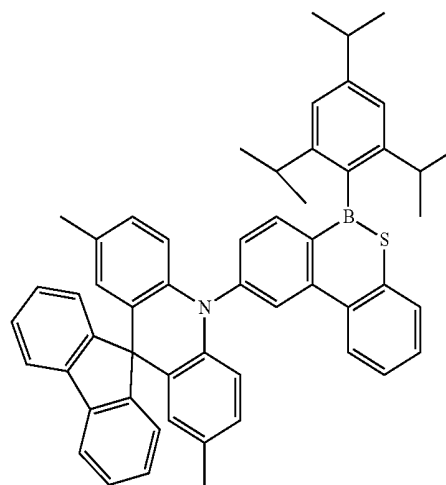

75

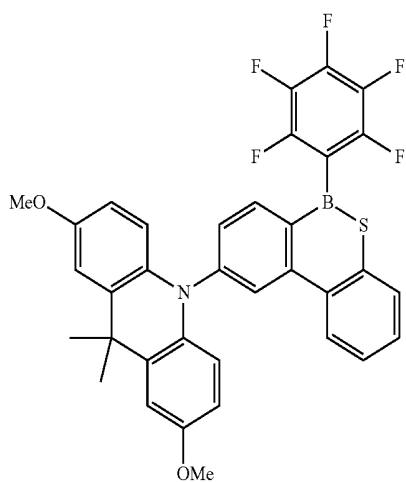

73

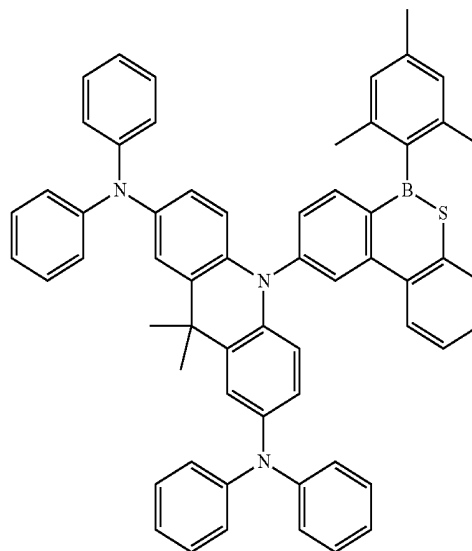

76

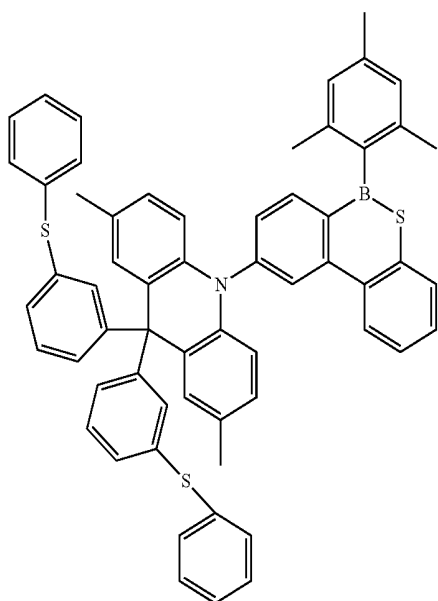

74

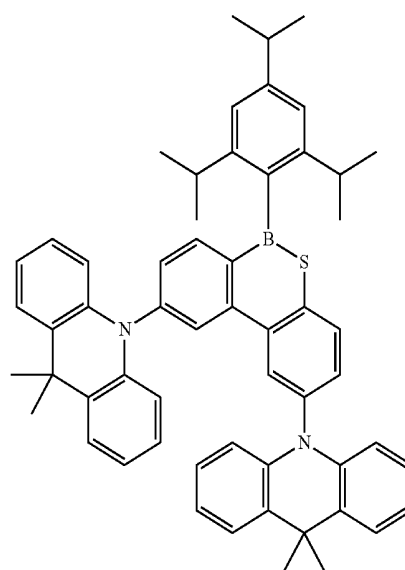

78

-continued

79

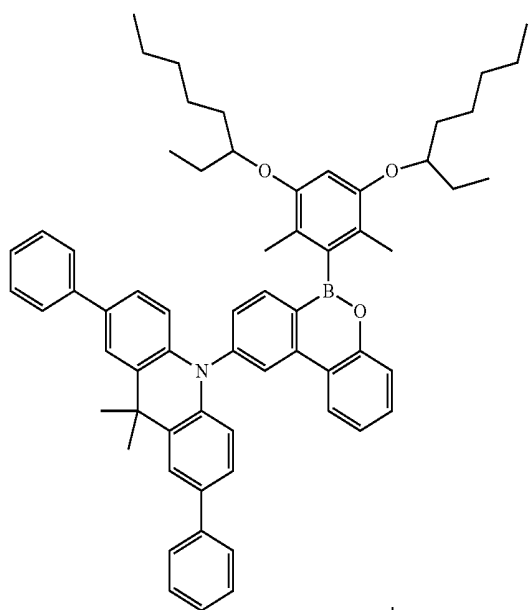

80

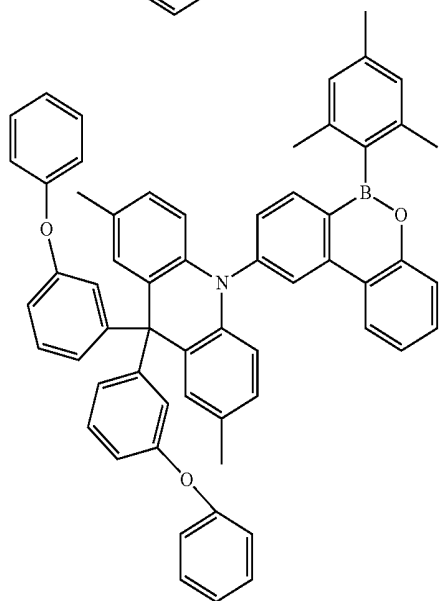

81

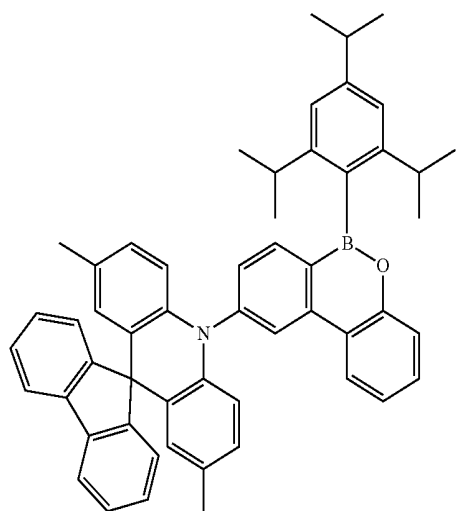

-continued

82

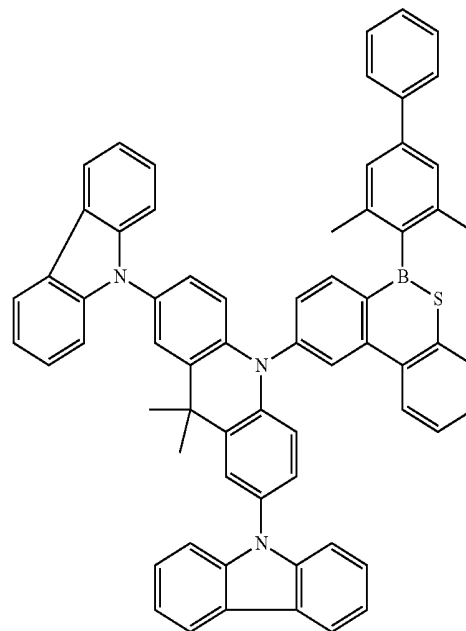

83

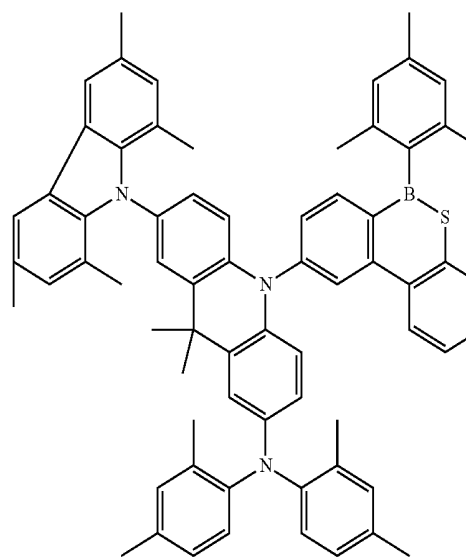

-continued

84

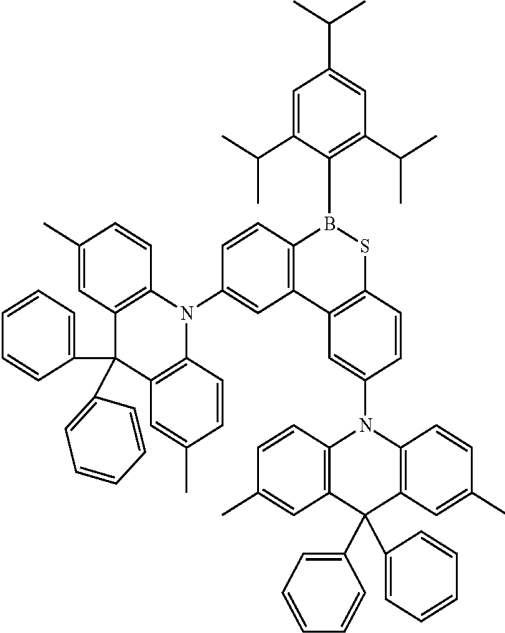

* * * * *

专利名称(译)	有机电致发光器件和用于有机电致发光器件的多环化合物		
公开(公告)号	US20200203627A1	公开(公告)日	2020-06-25
申请号	US16/597714	申请日	2019-10-09
[标]申请(专利权)人(译)	三星显示有限公司 国立大学法人九州大学		
申请(专利权)人(译)	三星DISPLAY CO., LTD. KYUSHU大学, 国立大学公司		
当前申请(专利权)人(译)	三星DISPLAY CO., LTD. KYUSHU大学, 国立大学公司		
[标]发明人	MIYAZAKI YUUKI FUJITA YOSHIMASA MATSUO KYOHEI YASUDA TAKUMA		
发明人	MIYAZAKI, YUUKI FUJITA, YOSHIMASA MATSUO, KYOHEI YASUDA, TAKUMA		
IPC分类号	H01L51/00 C07F5/02 C09K11/06		
CPC分类号	C09K2211/1018 H01L2251/552 C07F5/02 H01L51/0072 H01L51/5004 H01L51/5016 C09K11/06 C07F5/025 C07F7/0816		
优先权	1020180167210 2018-12-21 KR		
外部链接	Espacenet USPTO		

摘要(译)

提供一种有机电致发光器件，其中在发射层中包含包括电子给体和电子受体的多环化合物。电子给体包含an啞衍生物或二苯并氮杂line啞衍生物，并且电子受体包含作为环形成原子的B，与B直接键合的O或S以及其中三个或五个六角环耦合的杂环基。因此，可以实现具有高效率的有机电致发光器件。

